



特點 Features

- 為了追求最實用的效果，本公司設計此省空間，且方便安裝的產品。
- 可由兩個側面安裝配管。
- 有三種安裝本體方式。
- 配置四個溝槽，安裝埋入型作動感應檢出器（感應開關）。
- 全系列均附磁。
- Proven track record in manufacturing precision guided cylinders.
- Multi-Ports as standard enabling two direction mounting option.
- Flush fitting sensors.
- Inbuilt high density rubber pad absorbs energy at the end of stroke.
- Magnetic as standard.

規格 Specification

型號 Model	FCGB		
模組外形 Model			
作動方式 Acting type	複動型 Double acting		
氣缸內徑 Tube I.D. (mm)	12, 16	20, 25, 32, 40	50, 63
配管口徑尺寸 Port size	M5 × 0.8	PT 1/8	PT 1/4
使用流體 Medium	空氣 Air		
使用壓力範圍 Operating pressure range	1 ~ 9.9 kgf/cm ²		
耐壓力 Proof pressure	15 kgf/cm ²		
周圍溫度 Ambient temperature	-5°C ~ +60°C (不凍結 No freezing)		
給油 Lubrication	不需給油 Not required		
緩衝裝置 Cushion	NBR 緩衝墊片 With rubber cushion pad		
感應開關 Sensor switch	RCE, RCE1		

訂購代碼 Ordering Code

FCGB - 03 - 12 M 50 - BSP

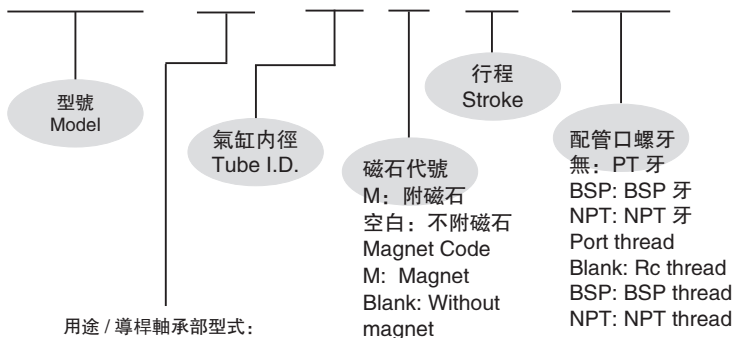

用途 / 導桿軸承部型式:
Purpose / Type of bearing

代號 Code	用途 / 軸承種類 Purpose / Type of bearing
03	阻擋型 / 滑動軸承 Stop / Slide bearing
23*	推出型 / 線性滾珠軸承 Push / Linear bush bearing

※ 此型僅要於連接塊上，組合一承載板，即可當做舉起型用。

※ Could attach a table for the use as a lifter.

感應開關安裝方式 Installation of sensor switch

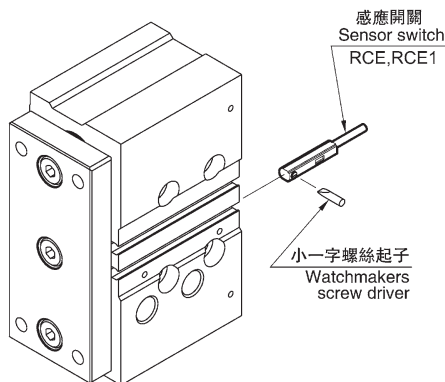

標準行程表 Table for standard stroke

型號 Series variety	軸承種類 Bearing type	內徑 Tube I.D.	行程 Stroke (mm)														
			10	20	25	30	40	50	75	100	125	150	175	200			
FCGB-03	滑動軸承 Slide bearing	Φ12															
		Φ16															
		Φ20															
		Φ25															
		Φ32*															
		Φ40															
		Φ50															
FCGB-23	線性滾珠軸承 Linear bush bearing	Φ12															
		Φ16															
		Φ20															
		Φ25															
		Φ32															
		Φ40															
		Φ50															
Φ63																	

*1. FCGB-03 型，缸徑 Φ32 者其最短的標準行程為 25mm。

2. 屬中間行程者，用大於其之規格之本體於活塞上加一墊塊。

*1. FCGB-03- Tube I.D. Φ32: 25mm for the shortest standard stroke.

2. Please consult us if stroke out of specification.

橫荷重圖表 Capacity graph

作阻擋使用時的容許性能
Capacity for the use as a stopper

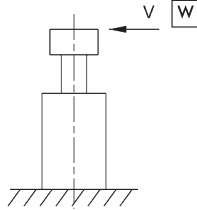

請注意：線性滾珠軸承式之導桿缸，不適於當阻擋用途。
Linear bush bearing type is not available as a stopper.

容許阻擋能力表 Stop capacity

FCGB-03... 行程 30mm 者
FCGB-03...30st

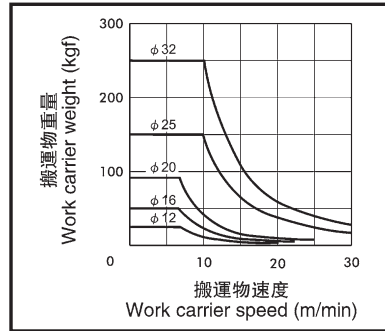

性能圖表 Capacity Φ12 ~ Φ32

常用橫荷重表 Normal lateral load

FCGB-03... 行程 30mm 者
FCGB-03...30st

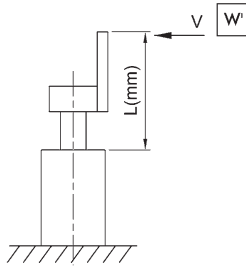
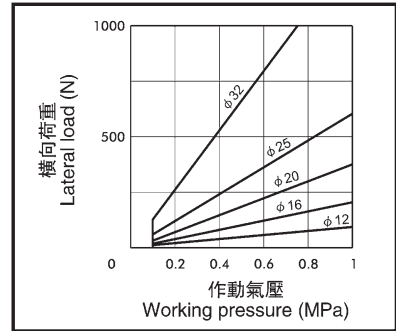

對於在連接塊上，固定一擋板使時，請依據下式關係，將 W' 換算成 W 當量值

換算用係數表 Coefficients for conversion

$$W = W' \times \frac{L}{l}$$

FCGB 系列 / Series	Φ12	Φ16	Φ20	Φ25	Φ32
l	40	42	42	42	44

W: 換算出的 W 當量值，仍須符合上述搬運物重量—速度關係圖
W: the maximum weight of the work carrier in the above graph for the stopper's capacity.

舉起型使用之偏心荷重 Capacity for the use as a lifter

作業起使用時的容許偏心荷重 (考慮作動氣壓 0.5MPa 情況時)
Allowable eccentricity load for the use as a lifter (at supply pressure 0.5Mpa)

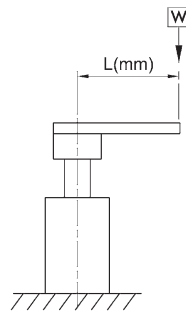

圖示 W 表氣缸作動時，距離導桿中心 Lmm 處，容許因動態所產生的荷重值
Show the dynamic allowable value at L(mm) eccentricity from the center of the guide rod.

滑動軸承型 Slide bearing

FCGB-03... 行程 10~50mm 者
FCGB-03...10~50st

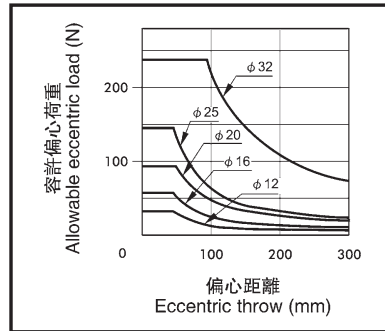

線性滾珠軸承型 Linear bush bearing

FCGB-03... 行程 10~50mm 者
FCGB-03...10~50st

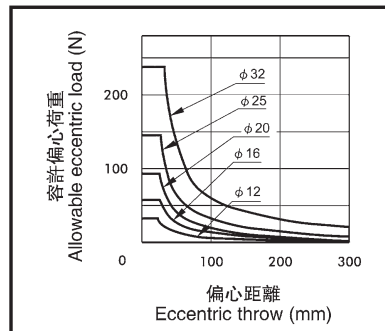

滑動軸承型 Slide bearing

FCGB-03... 行程 75~200mm 者
FCGB-03...75~200st

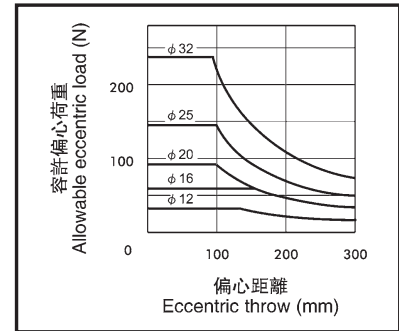

線性滾珠軸承型 Linear bush bearing

FCGB-03... 行程 75~200mm 者
FCGB-03...75~200st

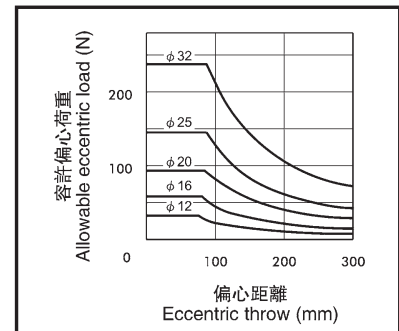

橫荷重表 Capacity table

容許橫向荷重: Allowable lateral load

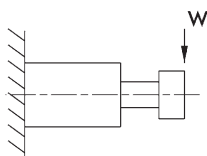

考慮驅動氣缸過程時，於導桿端部，所能承受，因動態所產生的最大荷重（指垂直於導桿軸心線的荷重）。

Shows the dynamic allowable value, when actuating the cylinder with lateral load W at the guide rods' top (vertical load against the guide rods).

容許旋轉扭矩: Allowable rotating torque

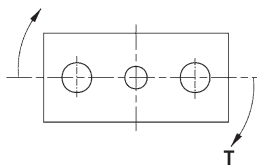

考慮驅動氣缸過程時，於導桿端部所能承受，因動態所產生的最大扭矩

Shows the dynamic allowable value, when actuating the cylinder with a rotating torque T at the guide rods' top.

不迴轉精度: (抵抗偏擺的能力) Anti-roll accuracy

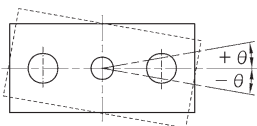

- 此精度值 θ 是以活塞桿為中心的偏擺角度作表示
- 此精度值 θ 忽略之導桿本身的撓度情況
- The values are the deflection angle against the piston rod.
- Exclusive factor of the guide rods' deflection.

(N)

氣缸內徑 Tube I.D.	軸承種類 Bearing type	行程 Stroke (mm)											
		10	20	25	30	40	50	75	100	125	150	175	200
Φ12	滑動軸承 Slide bearing	31	24	/	19	16	13	37	31	/	/	/	/
	線性滾珠軸承 Linear bush bearing	23	17	/	14	34	30	23	19	/	/	/	/
Φ16	滑動軸承 Slide bearing	50	39	/	32	27	24	54	45	/	/	/	/
	線性滾珠軸承 Linear bush bearing	36	29	/	24	59	52	40	33	/	/	/	/
Φ20	滑動軸承 Slide bearing	/	51	/	44	39	35	54	46	74	66	59	54
	線性滾珠軸承 Linear bush bearing	/	43	/	36	98	87	69	57	46	40	36	32
Φ25	滑動軸承 Slide bearing	/	68	/	59	52	46	72	61	98	88	79	72
	線性滾珠軸承 Linear bush bearing	/	67	/	56	148	132	105	87	70	62	55	50
Φ32	滑動軸承 Slide bearing	/	/	165	/	/	129	106	90	138	123	111	101
	線性滾珠軸承 Linear bush bearing	/	/	104	/	/	74	165	138	114	100	90	81

(N.m)

氣缸內徑 Tube I.D.	軸承種類 Bearing type	行程 Stroke (mm)											
		10	20	25	30	40	50	75	100	125	150	175	200
Φ12	滑動軸承 Slide bearing	0.64	0.48	/	0.39	0.32	0.28	0.75	0.63	/	/	/	/
	線性滾珠軸承 Linear bush bearing	0.47	0.35	/	0.29	0.71	0.62	0.4	0.38	/	/	/	/
Φ16	滑動軸承 Slide bearing	1.14	0.9	/	0.74	0.63	0.55	1.23	1.04	/	/	/	/
	線性滾珠軸承 Linear bush bearing	0.84	0.66	/	0.54	1.35	1.19	0.93	1.76	/	/	/	/
Φ20	滑動軸承 Slide bearing	/	1.14	/	1.21	1.07	0.95	1.49	1.25	2.03	1.81	1.63	1.48
	線性滾珠軸承 Linear bush bearing	/	1.19	/	0.99	2.69	2.4	1.89	1.56	1.26	1.1	0.98	0.88
Φ25	滑動軸承 Slide bearing	/	2.19	/	1.88	1.65	1.47	2.31	1.94	3.15	2.8	2.52	2.3
	線性滾珠軸承 Linear bush bearing	/	2.14	/	1.79	4.74	4.22	3.36	2.78	2.25	1.98	1.76	1.59
Φ32	滑動軸承 Slide bearing	/	/	6.61	/	/	5.16	4.23	3.59	5.52	4.93	4.45	4.06
	線性滾珠軸承 Linear bush bearing	/	/	4.17	/	/	2.95	6.6	5.52	4.56	4.02	3.59	3.24

氣缸內徑 Tube I.D.	軸承種類 Bearing type	不迴轉精度 Anti-roll accuracy
		θ
Φ12	滑動軸承 Slide bearing	$\pm 0.09^\circ$
	線性滾珠軸承 Linear bush bearing	$\pm 0.06^\circ$
Φ16	滑動軸承 Slide bearing	$\pm 0.08^\circ$
	線性滾珠軸承 Linear bush bearing	$\pm 0.06^\circ$
Φ20	滑動軸承 Slide bearing	$\pm 0.08^\circ$
	線性滾珠軸承 Linear bush bearing	$\pm 0.03^\circ$
Φ25	滑動軸承 Slide bearing	$\pm 0.07^\circ$
	線性滾珠軸承 Linear bush bearing	$\pm 0.05^\circ$
Φ32	滑動軸承 Slide bearing	$\pm 0.07^\circ$
	線性滾珠軸承 Linear bush bearing	$\pm 0.03^\circ$

FCGB-03/FCGB-23

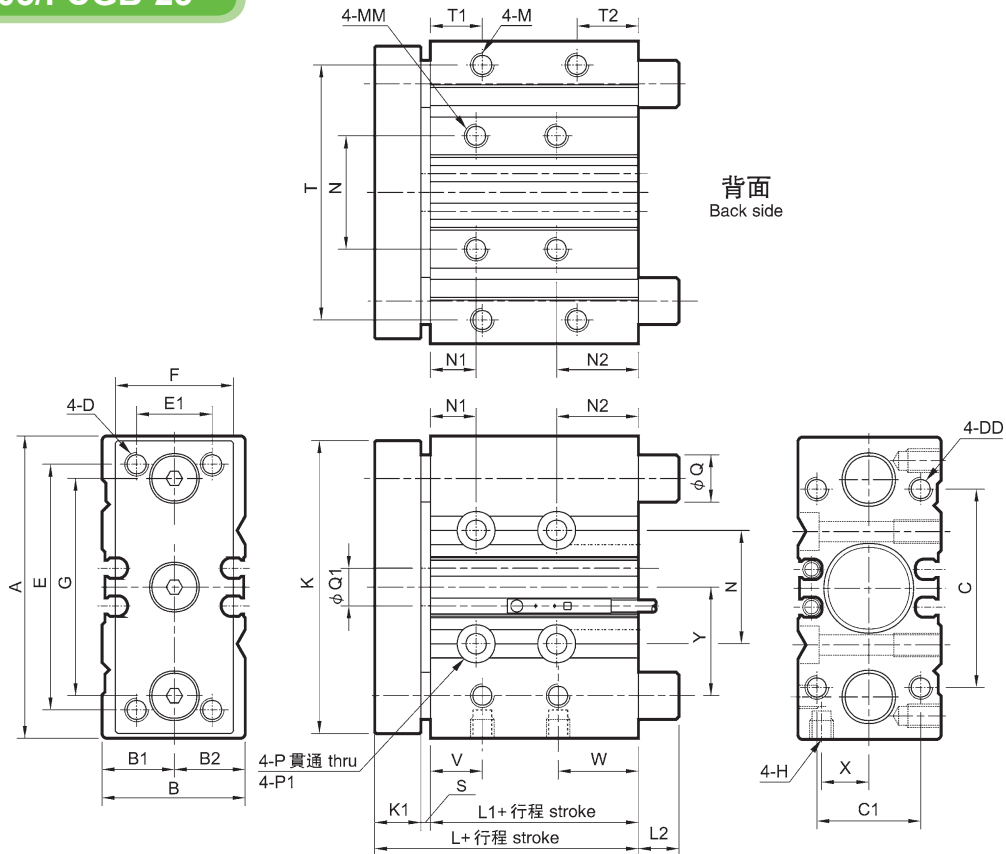

FCGB-03/FCGB-23

代號 Code 內徑 Tube I.D.	A	B	B1	B2	C	C1	D	DD	E	E1	F	G	H	K	K1	L	L1	L2	M
12	58	26	13	13	40	18	M4 × 0.7	M4 × 0.7 × 9 深 dp	48	14	22	41.5	M5 × 0.8	56	8	39	29		M4 × 0.7 × 7 深 dp
16	64	30	15	15	42	22	M5 × 0.8	M5 × 0.8 × 11 深 dp	52	16	25	46	M5 × 0.8	62	10	43	31		M5 × 0.8 × 8 深 dp
20	85	36	17	19	52	26	M5 × 0.8	M5 × 0.8 × 13 深 dp	60	18	30	55	PT 1/8	81	10	47	35	※	M5 × 0.8 × 7 深 dp
25	96	42	21	21	62	32	M6 × 1.0	M6 × 1.0 × 15 深 dp	70	26	38	65	PT 1/8	91	10	47.5	35.5		M6 × 1.0 × 9 深 dp
32	116	51	26	25	80	38	M8 × 1.25	M8 × 1.25 × 18 深 dp	96	30	48	80	PT 1/8	112	12	47.5	33.5		M8 × 1.25 × 11 深 dp

代號 Code 內徑 Tube I.D.	MM	N	N1	N2	P	P1	Q		Q1	S	T	T1	T2	V	W	X	Y
							FCGB-03	FCGB-23									
12	M5 × 0.8 × 10 深 dp	23	5	20	$\Phi 4.3$	$\Phi 8 \times 4.5$ 深 dp	8	6	6	2	50	12	12	11	15	8.5	19.5
16	M5 × 0.8 × 10 深 dp	24	5	22	$\Phi 4.3$	$\Phi 8 \times 4.5$ 深 dp	10	8	8	2	54	11	13	11	17	10	23
20	M6 × 1.0 × 12 深 dp	28	19	16	$\Phi 5.3$	$\Phi 9.5 \times 5.5$ 深 dp	12	10	10	2	64	11	14	12	23	11.5	24.5
25	M6 × 1.0 × 12 深 dp	34	22	12.5	$\Phi 5.3$	$\Phi 9.5 \times 5.5$ 深 dp	16	13	12	2	76	12	13.5	11	23.5	13.5	24
32	M8 × 1.25 × 16 深 dp	42	22	14.5	$\Phi 6.6$	$\Phi 11 \times 6.5$ 深 dp	20	16	16	2	100	12	16.5	11.5	25	16	31

L2 尺寸表 / Dimensions list

FCGB-03

內徑 Tube I.D.	行程 Stroke (mm)											
	10	20	25	30	40	50	75	100	125	150	175	200
12	0	0	/	0	0	0	18	18	/	/	/	/
16	0	0	/	0	0	0	21	21	/	/	/	/
20	/	0	/	0	0	0	14	14	31	31	31	31
25	/	0	/	0	0	0	14	14	31	31	31	31
32	/	/	/	20	20	20	20	20	42	42	42	42

FCGB-23

內徑 Tube I.D.	行程 Stroke (mm)											
	10	20	25	30	40	50	75	100	125	150	175	200
12	0	0	/	0	14	14	14	14	/	/	/	/
16	0	0	/	0	21	21	21	21	/	/	/	/
20	/	0	/	0	27	27	27	27	50	50	50	50
25	/	2	/	2	35	35	35	35	50	50	50	50
32	/	/	/	8	8	8	8	42	42	55	55	55

外觀尺寸 Dimensions $\Phi 40 \sim \Phi 63$

FCGB-03/FCGB-23

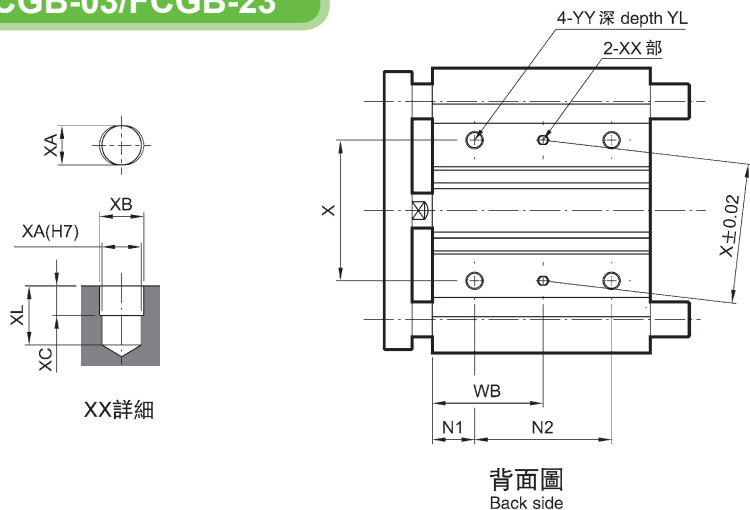

T溝尺寸
T groove size

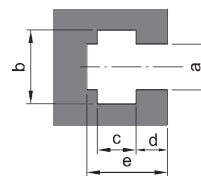

T溝尺寸 T groove size

內徑 Tube I.D.	a	b	c	d	e
40	6.5	10.5	5.5	4	11
50	8.5	13.5	7.5	4.5	13.5
63	11	17.8	10	7	18.5

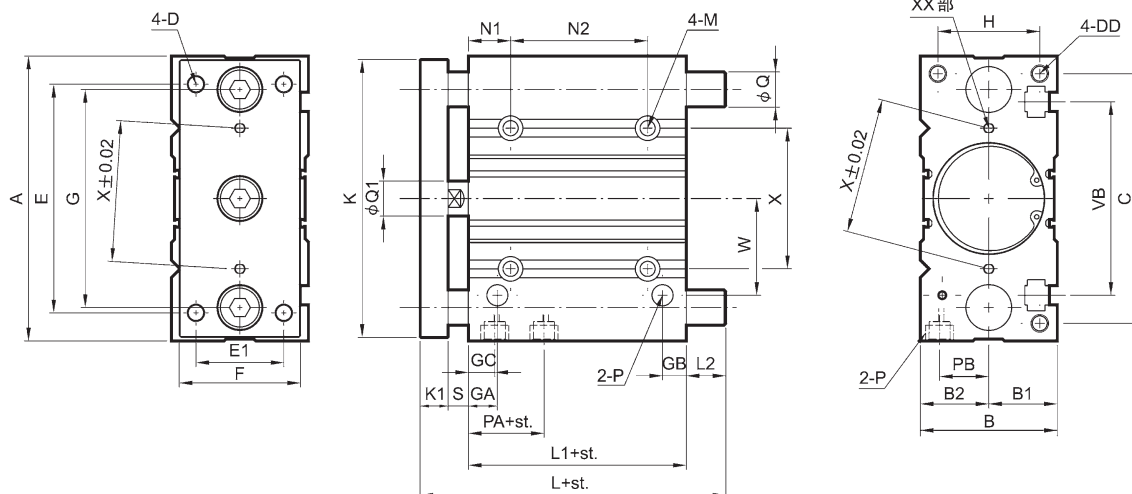

FCGB-03/FCGB-23

代號 Code 內徑 Tube I.D.	A	B	B1	B2	C	D	DD	E	E1	F	G	GA	GB	GC	H	K	K1	L1	M
40	120	54	27	27	106	M8 × 1.25	M8 × 1.25 × 20 深 dp	104	30	44	86	14	10	14	40	118	12	44	Φ6.6 貫通 thru, Φ11 × 7.5 深 dp, 沉孔 hole
50	148	64	32	32	130	M10 × 1.5	M10 × 1.5 × 22 深 dp	130	40	60	110	14	11	12	46	146	16	44	Φ8.6 貫通 thru, Φ14 × 9 深 dp, 沉孔 hole
63	162	78	39	39	142	M10 × 1.5	M10 × 1.5 × 22 深 dp	130	50	70	124	16.5	13.5	16.5	58	158	16	49	Φ8.6 貫通 thru, Φ14 × 9 深 dp, 沉孔 hole

代號 Code 內徑 Tube I.D.	N1	P	PA	PB	Q1	S	VB	W	X	XA ^{H7}	XB	XC	XL	YY	YL	N2			WB		
																25st	50,75,100st	100st 以上 above	25st	50,75,100st	100st 以上 above
40	22	PT 1/8	13	18	16	10	72	38	50	4	4.5	3	6	M8 × 1.25	16	24	48	124	34	46	84
50	24	PT 1/4	9	21.5	20	12	92	47	66	5	6	4	8	M10 × 1.5	20	24	48	124	36	48	86
63	24	PT 1/4	14	28	20	12	110	55	80	5	6	4	8	M10 × 1.5	20	28	52	128	38	50	88

FCGB-03

代號 Code 內徑 Tube I.D.	L		L2		Q
	25,50st	50st 以上 above	25,50st	50st 以上 above	
40	97	102	31	36	Φ20
50	106.5	118	34.5	46	Φ25
63	106.5	118	29.5	41	Φ25

FCGB-23

代號 Code 內徑 Tube I.D.	L			L2			Q
	25,50st	75,100st	100st 以上 above	25,50st	75,100st	100st 以上 above	
40	81	98	118	15	32	52	Φ16
50	93	114	134	21	42	62	Φ20
63	93	114	134	16	37	57	Φ20