

規格 Specification

型號 Type	FAC201N-01、02	FAC301N-02、03	FAC401N-03、04	FAC501N-06、08	FAC601N-06、08	
接管口徑 G Port Size	1/8" · 1/4"	1/4" · 3/8"	3/8" · 1/2"	3/4" · 1"	3/4" · 1"	
壓力表接管口徑 G Gauge Thread	1/8"					
工作介質 Fluid	壓縮空氣 Compressed Air					
使用壓力範圍 MPa Operating Pressure Range	0.15~0.85					
最大處理流量 L/min Max. Flow Rate	900	2000	3500	5000		
使用溫度範圍 °C Ambient Temperature	-10~60					
過濾精度 Filter Precision	5 μm 或 (or) 40 μm					
推薦使用油 Oil Recommended	ISO VG32					
杯子材質 Cup Material	聚碳酸酯 Polycarbonate					
構造 / 減壓閥 Structure	溢流型 Overflow Type					
附屬品 (標準裝備) Optional	防護罩 Guard Cup	-	●	●	●	●
	托架 Bracket	20T	30T	40T	50T	50T

注 1: FAC201A 系列防護罩可另選擇。注 2: FAC201A、FAC301A 系列短杯可另選擇。

Notes 1: The guard cup of FAC201A series can be optional.

Notes 2: The cups of FAC201A、FAC301A series can be optional.

訂購代碼 Ordering Code

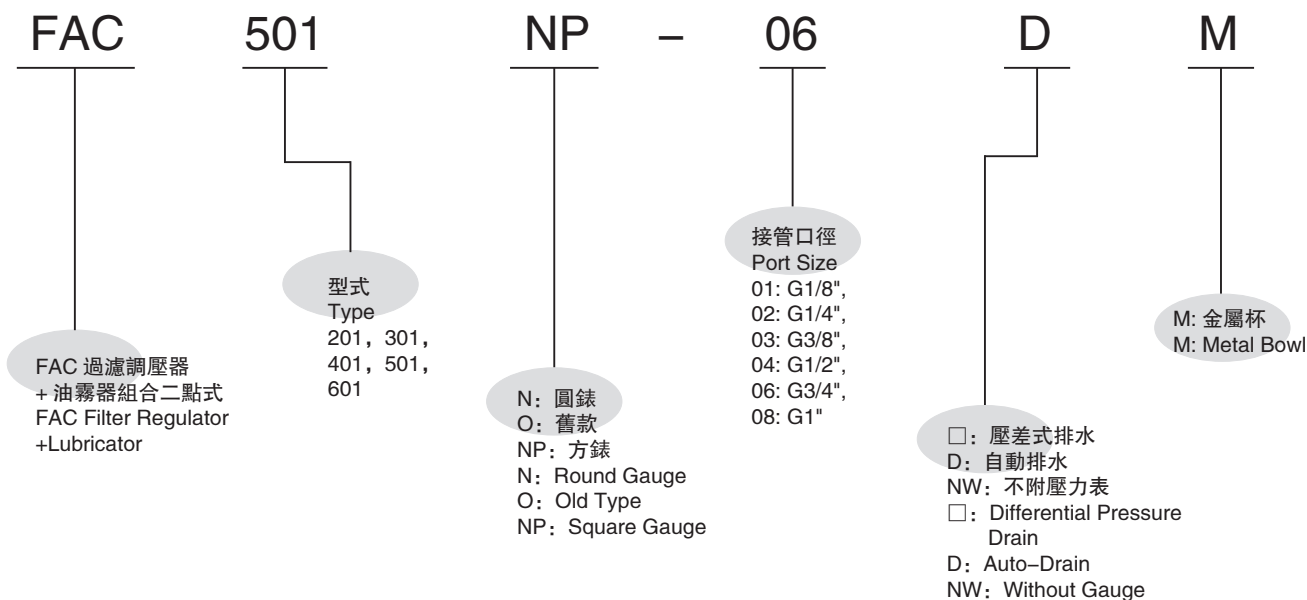

外觀尺寸 Overall Dimension

FAC201N-01、02

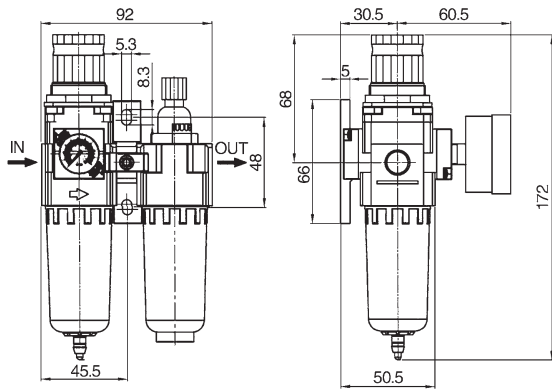

FAC301N-02、03

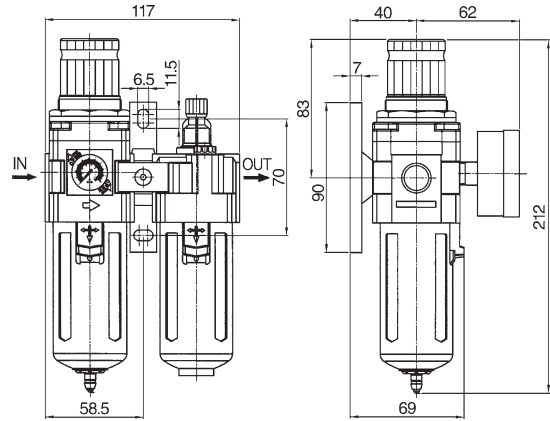

FAC401N-03、04

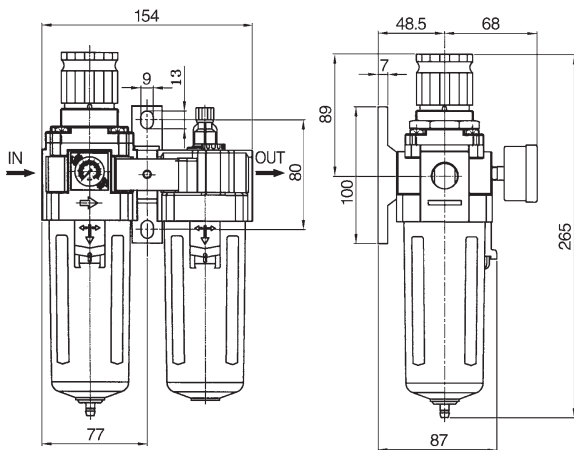

FAC501N-06、08

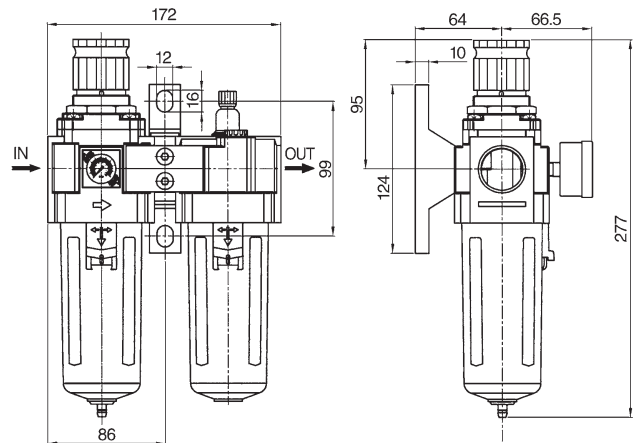

FAC601N-06、08

