

規格 Specification

型號 Type	FR/L-02	UFR/L-02、02J	UFR/L-03、03J	UFR/L-04、04J	UFR/L-06	UFR/L-08
接管口徑 G Port Size	1/4"	1/4"	3/8"	1/2"	3/4"	1"
壓力表接管口徑 G Gauge Thread	1/8"	1/4"				
工作介質 Fluid	壓縮空氣 Compressed Air					
使用壓力範圍 MPa Operating Pressure Range	0.15~0.85					
最大處理流量 L/min Max. Flow Rate	1850	2800		7900	8100	
使用溫度範圍 °C Ambient Temperature	-10~60					
過濾精度 Filter Precision	5 μm 或 (or) 40 μm					
推薦使用油 Oil Recommended	ISO VG32					
杯子材質 Cup Material	聚碳酸酯 Polycarbonate					
構造 / 減壓閥 Structure	活塞型 Piston Type					
防護罩 Optional	-	●	●	●	●	●

訂購代碼 Ordering Code

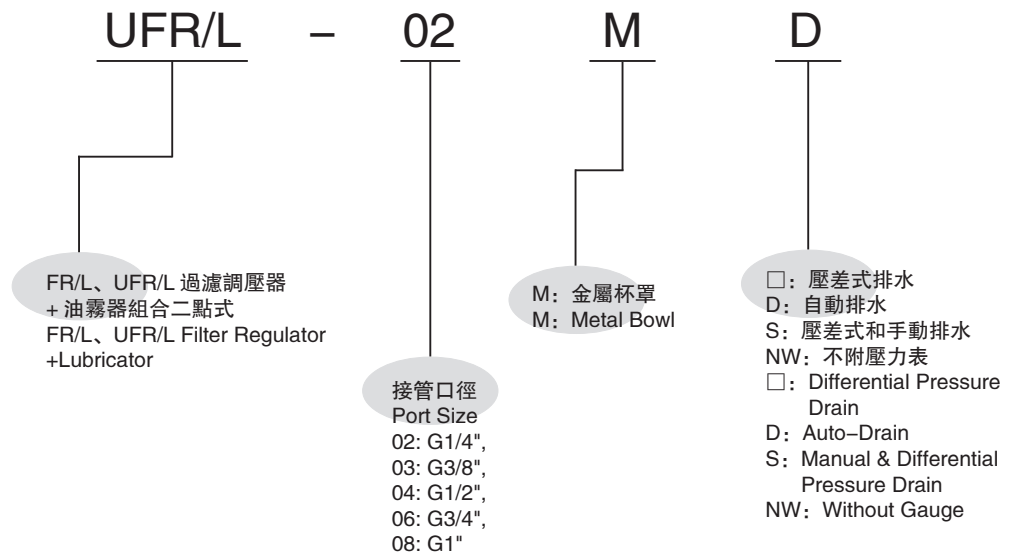

外觀尺寸 Overall Dimension

FR/L-02

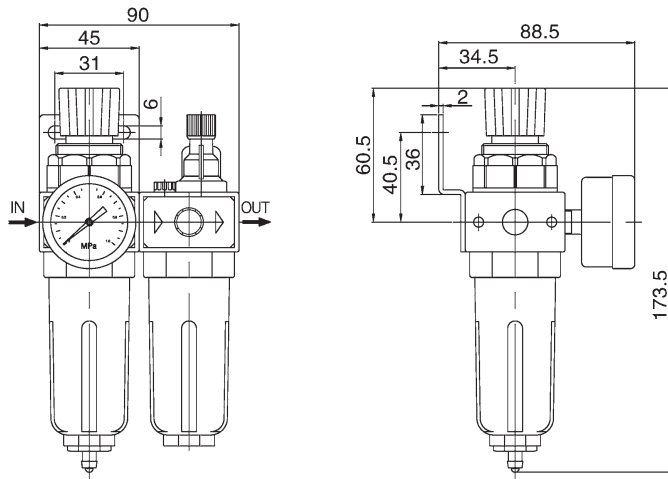

UFR/L-02、03、04

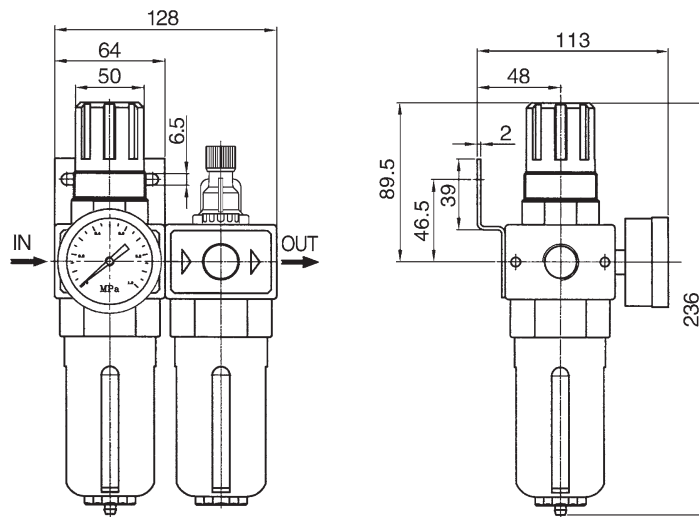

UFR/L-06、08

