

### 規格 Specification

型號 Type	UFRLH-02	UFRLH-03	UFRLH-04	UFRLH-06	UFRLH-08
接管口徑 G Port Size	1/4"	3/8"	1/2"	3/4"	1"
壓力表接管口徑 G Gauge Thread	1/4"				
工作介質 Fluid	壓縮空氣 Compressed Air				
使用壓力範圍 MPa Operating Pressure Range	0.15~1.6				
最大處理流量 L/min Max. Flow Rate	2800		7900		8100
使用溫度範圍 °C Ambient Temperature	-10~60				
過濾精度 Filter Precision	5 μm 或 (or) 40 μm				
推薦使用油 Oil Recommended	ISO VG32				
杯子材質 Cup Material	聚碳酸酯 Polycarbonate				
構造 / 減壓閥 Structure	活塞型 Piston Type				
防護罩 Optional	●				

### 訂購代碼 Ordering Code

UFRLH

-

02

D

UFRLH 過濾器 + 調壓器  
+ 油霧器組合三點式  
UFRLH Filter + Regulator  
+ Lubricator

接管口徑  
Port Size  
02: G1/4", 03: G3/8",  
04: G1/2", 06: G3/4",  
08: G1"

□: 壓差式排水  
D: 自動排水  
NW: 不附壓力表  
□: Differential Pressure Drain  
D: Auto-Drain  
NW: Without Gauge

### 外觀尺寸 Overall Dimension

UFRLH-02、03、04

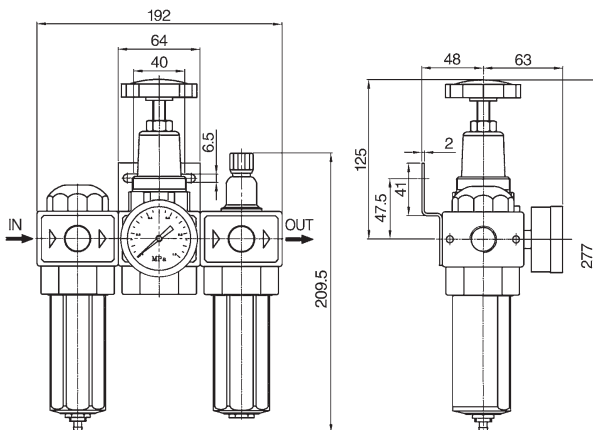

UFRLH-06、08

