



### 特點 Feature

常用于自動排除管道低處、冷凍式空氣乾燥機、油水分離器、貯氣罐及各種空氣過濾器底部等處的積水。可安裝在不便于進行人工排放污水的地方，如高處、低處、狹溢處；特別是安裝在用氣量較大、放水次數較頻繁的地方，可防止人工排水被遺忘而造成壓縮空氣被冷凝水重新污染。

It is usually used to automatically drain water at low points of air system including pipes, air dryer, oil and water separator, air tank and various air filters, suitable to be mounted at places not convenient for manual water discharge, i.e. high and low points or places with small space, especially where air flow is high and water discharge is frequent, to prevent compressed air from re-contamination in case operator forget to discharge the water.

### 規格 Specification

型號 Type	FAD402-04	FAD402-06、08
工作介質 Fluid	壓縮空氣 Compressed Air	
進氣接管口徑 G Input Port Size	1/2"	3/4"、1"
排氣接管口徑 G Output Size	3/8"	1/8"
使用壓力範圍 MPa Operating Pressure Range	0.1~1	
使用溫度範圍 °C Ambient Temperature Range	-5~60	

### 訂購代碼 Ordering Code

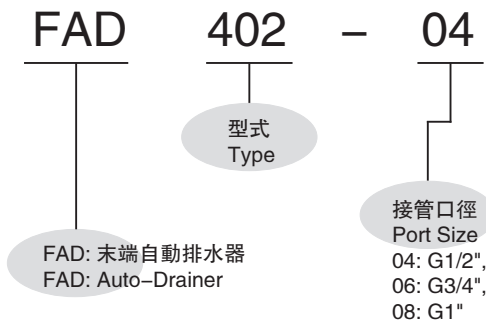

### 外觀尺寸 Overall Dimension

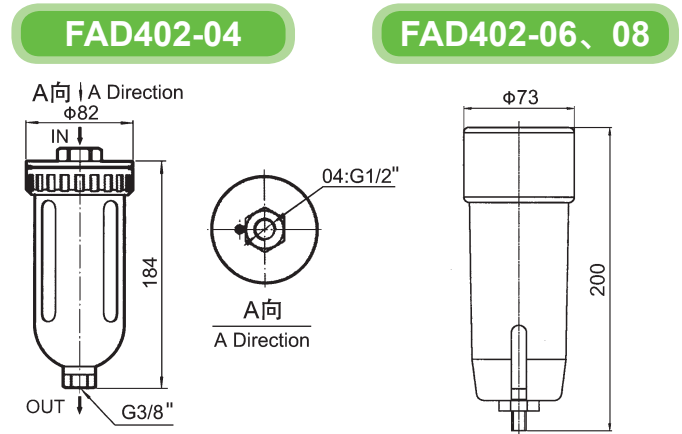

### 外觀尺寸 Overall Dimension

### 自動放水器 / Automatic Drainer

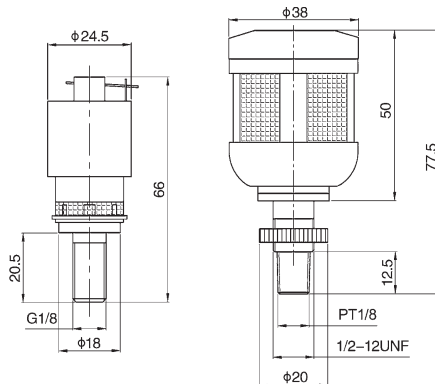

### 特點 Feature

本產品安裝在空氣過濾器、空氣過濾減壓閥的水杯底部，能自動排放積聚在水杯中的冷凝水。

It is mounted at the bottom of automatic drainer, air filter, and the bowl of compressed air relief valve, to automatically discharge the accumulated condensate.