

規格 Specification



內徑 Tube I.D. (mm)	32	40	50	63	80	100	125
動作形式 Operation	複動型 Double Acting						
工作介質 Working Medium	空氣 Air						
固定型式 Mountings	基本型 Basic FA型/type FB型/type CA型/type CB型/type LB型/type YB型/type						
使用壓力範圍 Operating Pressure Range	1 ~ 9.0 Kg/cm ²						
保證耐壓力 Proof Pressure	13.5 Kg/cm ²						
使用溫度範圍 Operating Temperature Range	0 ~ 70°C						
使用速度範圍 Operating Speed Range	50 ~ 800mm/s						
緩衝型式 Cushion	可調緩衝 Adjustable Cushion						
緩衝行程 Adjustable Cushion Stroke	20mm			26mm			
接管口徑 Port Size	G1/8"	G1/4"	G3/8"		G1/2"		

氣缸訂購代碼 Ordering Code

ASI - D - 50

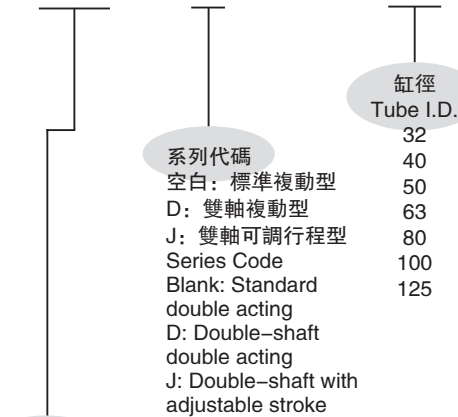

型號
ASI: ISO15552 標準氣缸
Series
ASI: ISO 15552
Standard cylinder

系列代碼
空白: 標準複動型
D: 雙軸複動型
J: 雙軸可調行程型
Series Code
Blank: Standard
double acting
D: Double-shaft
double acting
J: Double-shaft with
adjustable stroke

缸徑
Tube I.D.
32
40
50
63
80
100
125

M 50 - 10 - LB

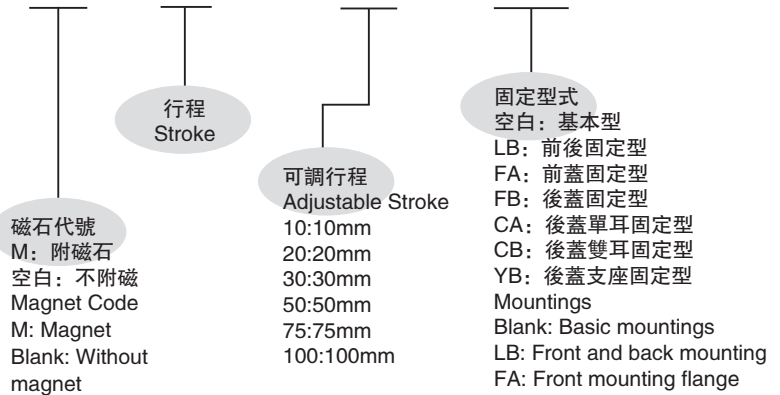

磁石代號
M: 附磁石
空白: 不附磁
Magnet Code
M: Magnet
Blank: Without
magnet

可調行程
Adjustable Stroke
10:10mm
20:20mm
30:30mm
50:50mm
75:75mm
100:100mm

固定型式
空白: 基本型
LB: 前後固定型
FA: 前蓋固定型
FB: 後蓋固定型
CA: 後蓋單耳固定型
CB: 後蓋雙耳固定型
YB: 後蓋支座固定型
Mountings
Blank: Basic mountings
LB: Front and back mounting
FA: Front mounting flange
FB: Back mounting flange
CA: Back clevis
(Single earring)
CB: Back hinge
(Double earring)
YB: Back hinge

*ASI系列標準氣缸全部為附磁型
*All ASI series standard cylinder are with magnet.

行程 Stroke

內徑 Tube I.D.	標準行程 Standard Stroke	最大行程 Max. Stroke	容許行程 Allowable Stroke
32	25 50 75 80 100 125 150 160 175 200 250 300 350 400 450 500	1000	2000
40	25 50 75 80 100 125 150 160 175 200 250 300 350 400 450 500 600 700 800	1200	2000
50	25 50 75 80 100 125 150 160 175 200 250 300 350 400 450 500 600 700 800 900 1000	1200	2000
63	25 50 75 80 100 125 150 160 175 200 250 300 350 400 450 500 600 700 800 900 1000	1500	2000
80	25 50 75 80 100 125 150 160 175 200 250 300 350 400 450 500 600 700 800 900 1000	1500	2000
100	25 50 75 80 100 125 150 160 175 200 250 300 350 400 450 500 600 700 800 900 1000	1500	2000
125	25 50 75 80 100 125 150 160 175 200 250 300 350 400 450 500 600 700 800 900 1000	1500	2000

ASI

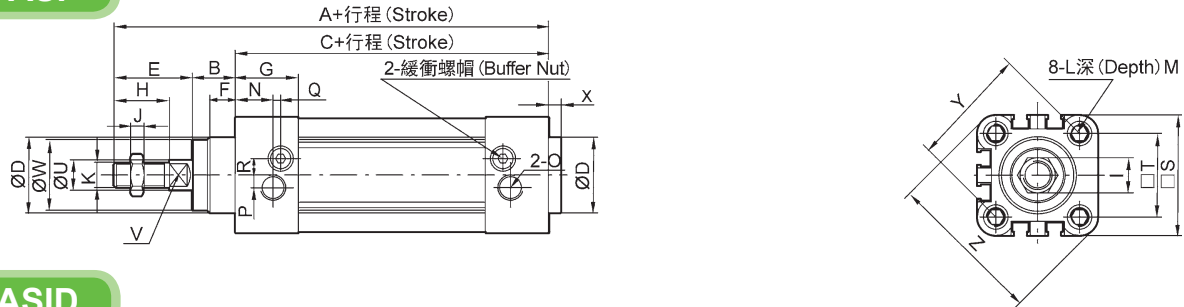

ASID

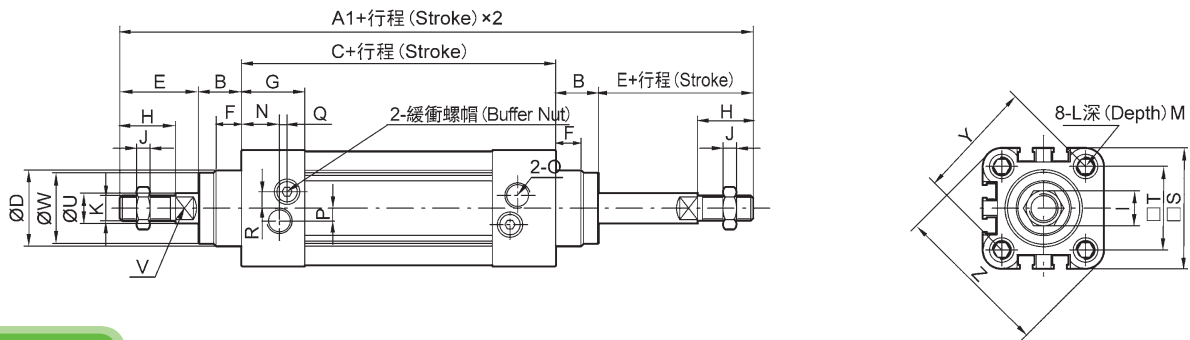

ASIJ

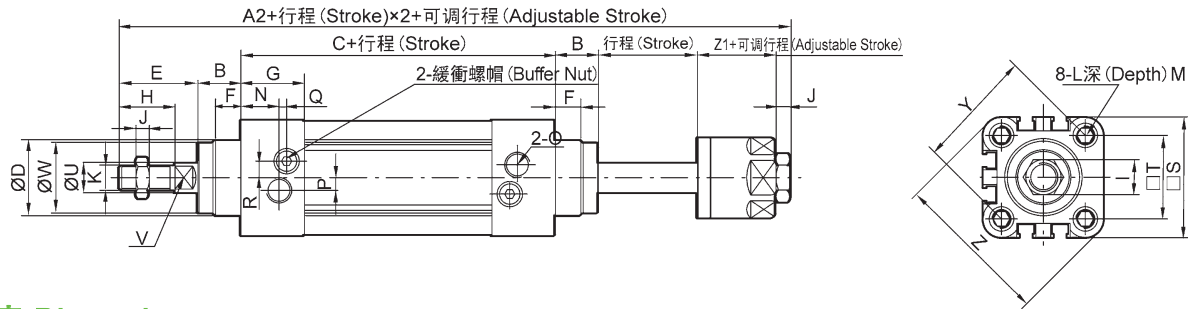

尺寸表 Dimension

符號 Symbol 缸徑 Tube I.D.	A	A1	A2	B	C	D	E	F	G	H	I	J	K	L
32	142	190	185	16	94	30	28	10	25	22	17	6	M10x1.25	M6
40	159	213	207	20	105	35	32	10	29.5	24	17	7	M12x1.25	M6
50	175	244	233	27	106	40	42	10	32	32	23	8	M16x1.5	M8
63	190	258	247	26	122	45	40	10	36	32	23	8	M16x1.5	M8
80	214	301	288	35	127	45	53	10	37	40	26	10	M20x1.5	M10
100	229	321	308	40	137	55	55	10	39	40	26	10	M20x1.5	M10
125	277	394	378	46	160	60	74	10	43.5	54	40	10	M27x2	M12

符號 Symbol 缸徑 Tube I.D.	M	N	O	P	Q	R	S	T	U	V	W	X	Y	Z	Z1
32	12	15	G1/8	5	3	6.5	45	32.5	12	10	28	4	46	58.7	21
40	12	17.5	G1/4	7	3	7	52	38	16	13	33	4	53.7	68	21
50	12	20	G1/4	7	3	9	65	46.5	20	17	38	4	65.8	84.5	23
63	12	22	G3/8	8	5	9	76	56.5	20	17	38	4	79.9	99.6	23
80	15	23	G3/8	10	5	12	94	72	25	22	43.5	5	101.8	123.8	29
100	15	26	G1/2	10	5	14	112	89	25	22	47	6	125.9	148.9	29
125	20	29	G1/2	10	5	14	134	110	32	27	53	7	156.9	179.6	40.5

LB 腳架 Foot

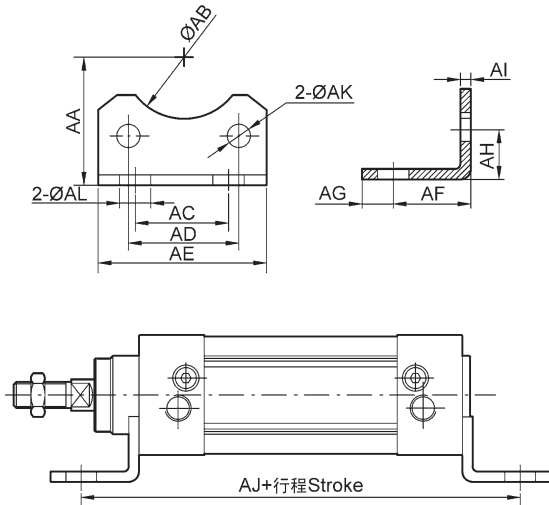

缸徑 Tube I.D. 符號 Symbol	32	40	50	63	80	100	125
AA	32	36	45	50	63	71	90
AB	30	35	40	45	45	55	60
AC	32	36	45	50	63	75	90
AD	32.5	38	46.5	56.5	72	89	110
AE	46.5	52.5	65	75	94.5	114.5	140
AF	24	28	32	32	41	41	45
AG	9	11	11	14	14	16	18
AH	15.8	17	21.8	21.8	27	26.5	35
AI	3.2	3.2	3.2	3.6	4.5	4.5	8
AJ	142	161	170	185	210	220	250
AK	6.5	6.5	8.5	8.5	10.5	10.5	12.5
AL	7	10	10	10	12	14.5	16.5

FA / FB 法蘭 Flange

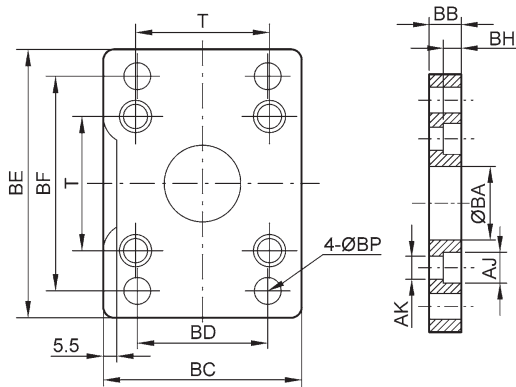

缸徑 Tube I.D. 符號 Symbol	32	40	50	63	80	100	125
BA	30.3	35.3	40.3	45.3	45.3	55.3	60.3
BB	10	10	12	12	16	16	20
BC	45	52	65	76	94	112	140
BD	32	36	45	50	63	75	90
BE	80	90	110	120	150	175	224
BF	64	72	90	100	126	150	180
BH	6.5	6.5	8.5	8.5	10.5	10.5	15
AJ	10.5	10.5	13.5	13.5	16.5	16.5	19
AK	6.5	6.5	8.5	8.5	10.5	10.5	12.5
BP	7	9	9	9	12	14	16
T	32.5	38	46.5	56.5	72	89	110

CA 單耳環 Hinge

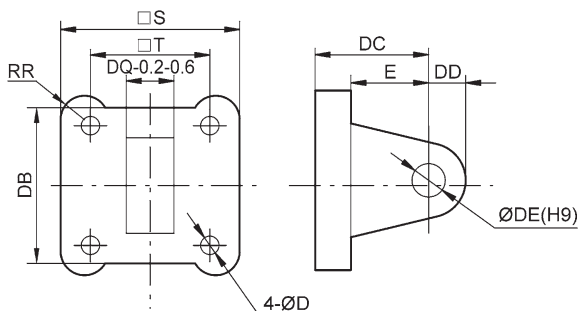

缸徑 Tube I.D. 符號 Symbol	32	40	50	63	80	100	125
S	45	52	65	76	94	112	140
T	32.5	38	46.5	56.5	72	89	110
RR	6.5	6.5	9	9.5	11	11.5	12
DB	34	41	54	65	83	101	123
DC	22	25	27	32	36	41	50
DD	10	11	13	16	16	20	25
DE	10	12	12	16	16	20	25
DQ	26	28	32	40	50	60	70
D	6.5	6.5	8.5	8.5	10.5	10.5	12.5
E	14	17	17	22	24	25	30

CB 雙耳環 Hinge

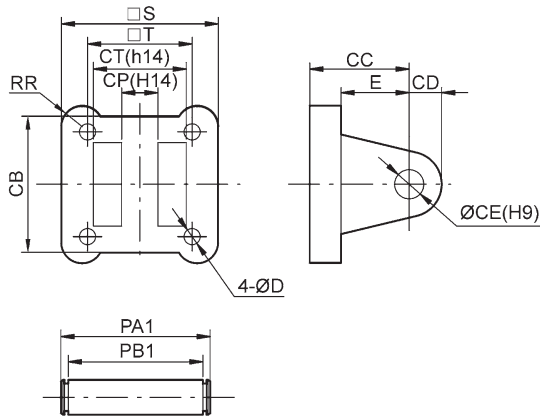

缸徑 Tube I.D. 符號 Symbol	32	40	50	63	80	100	125
S	45	52	65	76	94	112	140
T	32.5	38	46.5	56.5	72	89	110
D	6.5	6.5	8.5	8.5	10.5	10.5	12.5
E	14	17	17	22	24	25	30
RR	6.5	6.5	9	9.5	11	11.5	12
CB	34	41	54	65	83	101	123
CC	22	25	27	32	36	41	50
CD	10	11	13	16	16	20	25
CE	10	12	12	16	16	20	25
CP	26	28	32	40	50	60	70
CT	45	52	60	70	90	110	120
PA1	53	60	68	78	100	120	130
PB1	46.5	53.5	61.5	71.5	91.5	111.5	121.5

YB 支座 Hinge

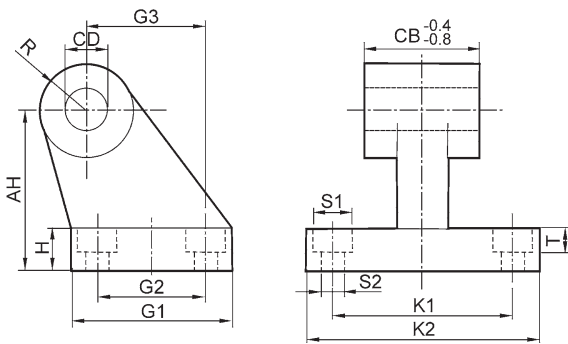

缸徑 Tube I.D. 符號 Symbol	32	40	50	63	80	100	125
AH	32	36	45	50	63	71	90
H	8	10	12	12	14	15	20
CD	10	12	12	16	16	20	25
G1	31	35	45	50	60	70	90
G2	18	22	30	35	40	50	60
G3	21	24	33	37	47	55	70
CB	26	28	32	40	50	60	70
K1	38	41	50	52	66	76	94
K2	51	54	65	67	86	96	124
S1	11	11	14	14	17	17	20
S2	6.6	6.6	9	9	11	11	14
T	1.6	1.6	1.6	1.6	2.5	2.5	3.2
R	10	11	13	15	15	19	22.5