



特點 Features

- 免給油：
採用含油合金，特殊軸承襯套，使活塞桿無需給油。
- 高品質，耐久佳：
氣壓缸採用高級不銹鋼材質，更具耐磨、腐蝕性。
- 標準化的設計：
大多數零件均可與國際標準 ISO 規格互相替換。
- 可承製非標準規格：
對各種桿端型尺寸及型錄規定以外之行程，請與本公司聯繫承製。
- 多樣化支架：
多種固定式及非固定式支架，供客戶選擇。
- 全系列均附磁

- Non lubrication
- Special housing and bushing enables self lubrication of piston rod. High quality long service life
 - Hard anodised stainless steel cylinder tubes offer a high resistance to corrosion and low internal friction.
 - Cylinder mountings, available with a comprehensive range of accessories for rigid or flexible mounting.
 - Operation, with the exception of FA-11, single and doubling type available-FA-13/15. Magnetic as standard.

規格 Specification

型號 Model		FA				
氣缸內徑 Tube I.D. (mm)		16	20	25	32	40
配管口徑尺寸 Port Size		M5 x 0.8	PT 1/8			
使用流體 Medium		空氣 Air				
最大使用壓力 Max. Operating Pressure		7 kgf/cm ²				
最小使用壓力 Min. Operating Pressure	複動 Double	0.6 kgf/cm ²				
	單動 Single	1.5 kgf/cm ²				
耐壓力 Proof Pressure		10 kgf/cm ²				
周圍溫度 Ambient Temperature		-5°C ~ +60°C (不凍結 No freezing)				
給油 Lubricator		不需給油 Not required				
使用速度範圍 Available Speed Range		50-500mm/sec				
感應開關 (束帶) Sensor Switch (band)	RD-201	搭配 Matching the BA20-BA40 束帶 band				
	RCM	搭配 Matching the BGS20-BGS40 束帶 band				
	RCB	搭配 Matching the BM16-BM40 束帶 band				
	RCS	搭配 Matching the BJ16 束帶 band				

標準行程表 Table for standard stroke

	氣缸內徑 Tube I.D.	行程 Stroke (mm)
單動型 Single Acting	Φ16	15, 25, 50, 75, 100
	Φ20, 25, 32	15, 25, 50, 75, 100, 125, 150
複動型 Double Acting	Φ16	15, 25, 50, 75, 100, 125, 150, 200, 250, 300, 350, 400, 450, 500
	Φ20, 25, 32, 40	15, 25, 50, 75, 100, 125, 150, 200, 250, 300, 350, 400, 450, 500

- ※ 非標準行程亦可承製，請洽業務人員。
- ※ Stroke out of specification is also available.
- ※ Please consult us if stroke out of specification.

氣缸訂購代碼 Ordering Code

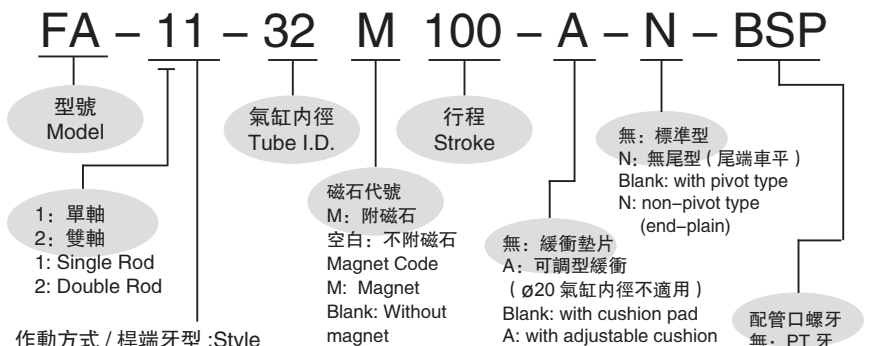

作動方式 / 桿端牙型 : Style

代號 Code	記號 Symbol	說明 Description
1	1	複動外牙 Double acting/Male thread
1	3	引入單動外牙 Single acting/ Normally extended male thread
1	5	押出單動外牙 Single acting/ Normally returned male thread
2	1	雙軸複動外牙 Double rod/Male thread
2	7	雙軸可調行程外牙 Double rod/Adjustable male thread please make "adjustable distance(mm)" at order list

安裝配件 Mounting accessories

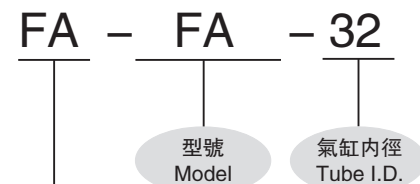

安裝型式: Mounting type

	LB
	FA
	FB
	SDB
	Y
	I

複動型 / 外觀尺寸 Dimensions / Double acting $\phi 16 \sim \phi 40$

11

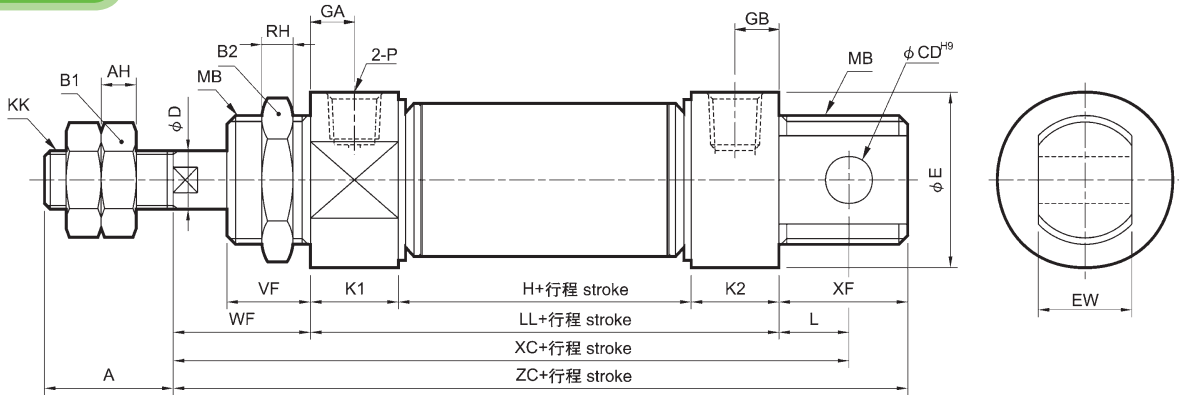

21

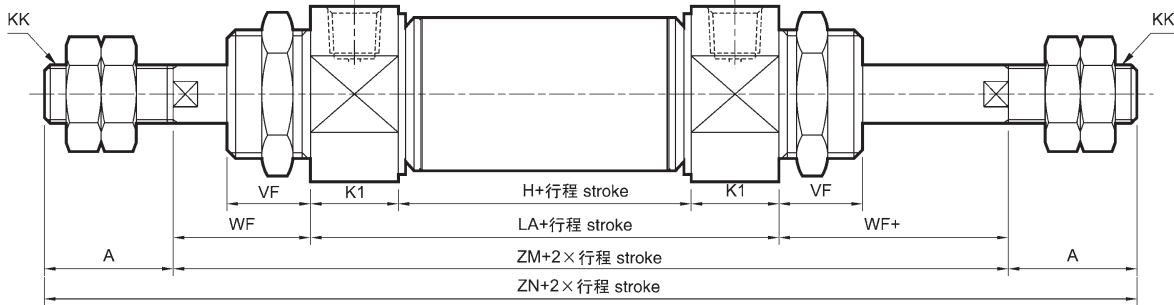

27

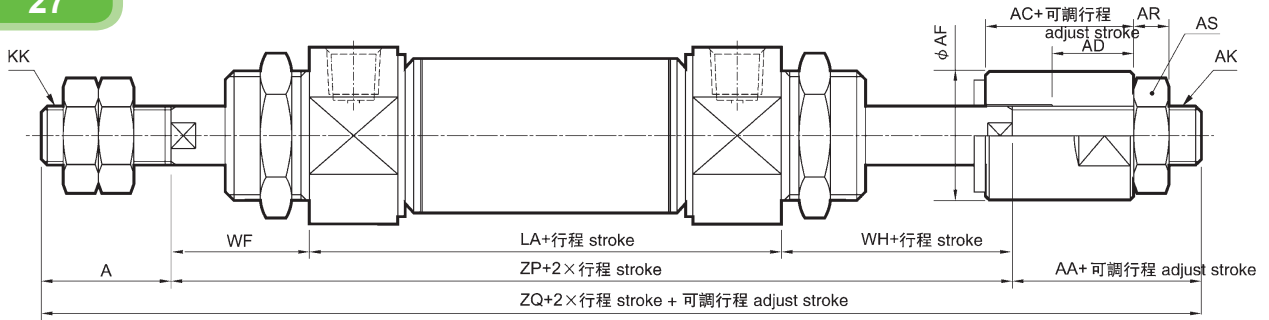

代號 Code 內徑 Tube I.D.	A	AA	AC	AD	AF	AH	AR	AS	AK	B1	B2	CD	D	E	EW	GA	GB	H	KK
16	16	16	13	7.5	12	5	4	8	M5 x 0.8	10	22	6	6	19.7	12 ^{-0.05} _{-0.4}	5	5	34	M6 x 1.0
20	20	19	15	9.5	16	5	5	13	M8 x 1.25	13	30	8	8	26.7	16 ^{-0.05} _{-0.4}	7.5	7.5	40	M8 x 1.25
25	22	19	15	9.5	16	5	5	13	M8 x 1.25	17	30	8	10	29.7	16 ^{-0.05} _{-0.4}	7.5	7.5	40	M10 x 1.25
32	22	18	12	7	20	5	6	17	M10 x 1.25	17	32	10	12	36	16 ^{-0.05} _{-0.4}	7.5	10.5	37	M10 x 1.25
40	30	18	12	7	30	7	7	19	M12 x 1.25	19	41	12	14	45	20 ^{-0.05} _{-0.4}	7.5	10.5	42	M12 x 1.25

代號 Code 內徑 Tube I.D.	K1	K2	L	LA	LL	MB	P	RH	VF	WF	WH	XC	XF	ZC	ZM	ZN	ZP	ZQ
16	10	10	9	54	54	M16 x 1.5	M5 x 0.8	6	12	22	19.5	85	16	92	98	130	95.5	127.5
20	15	15	12	70	70	M22 x 1.5	PT 1/8	6	12	18	19.5	100	21	109	106	146	107.5	146.5
25	15	15	12	70	70	M22 x 1.5	PT 1/8	6	15	27	22.5	109	21	118	124	168	119.5	160.5
32	15	18	14	67	70	M24 x 2.0	PT 1/8	8	18	30	24	114	24	124	127	171	121	161
40	15	18	16	72	75	M30 x 2.0	PT 1/8	8	17	27	24	118	28	130	126	186	123	171

感應開關安裝 Installation of sensor switch $\Phi 20 \sim \Phi 40$

感應開關 Sensor switch: RD-201

感應開關束帶 Sensor switch band: PN**

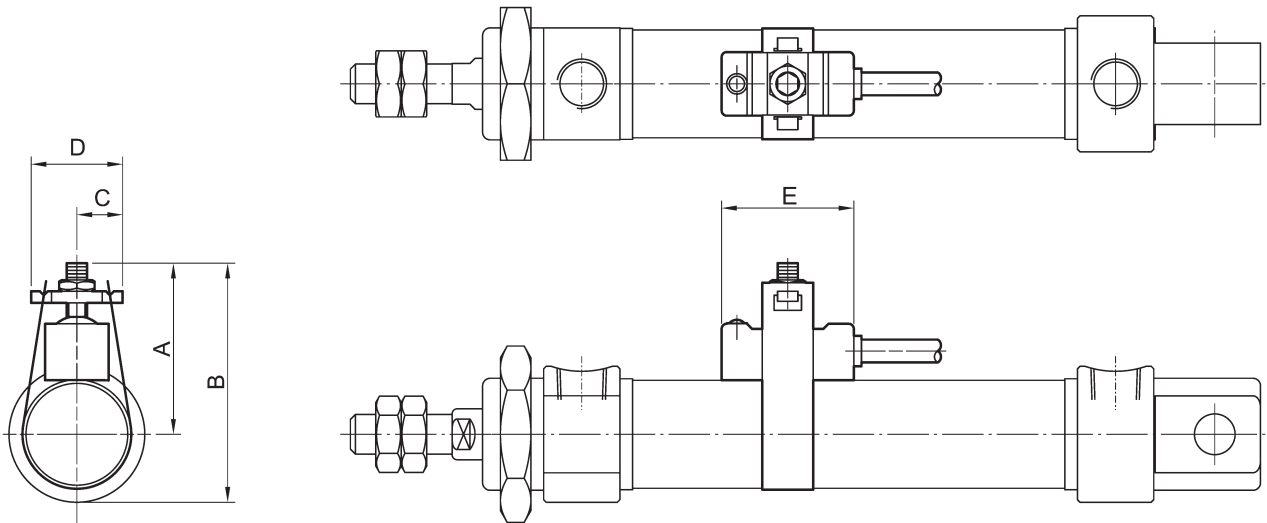

代號 Code 內徑 Tube I.D.	A	B	C	D	E
20	33	46.5	9	18	26
25	35.5	50.5	9	18	26
32	39	57	9	18	26
40	43	65.5	9	18	26

感應開關 Sensor switch: RD-201

感應開關束帶 Sensor switch band : BGS**

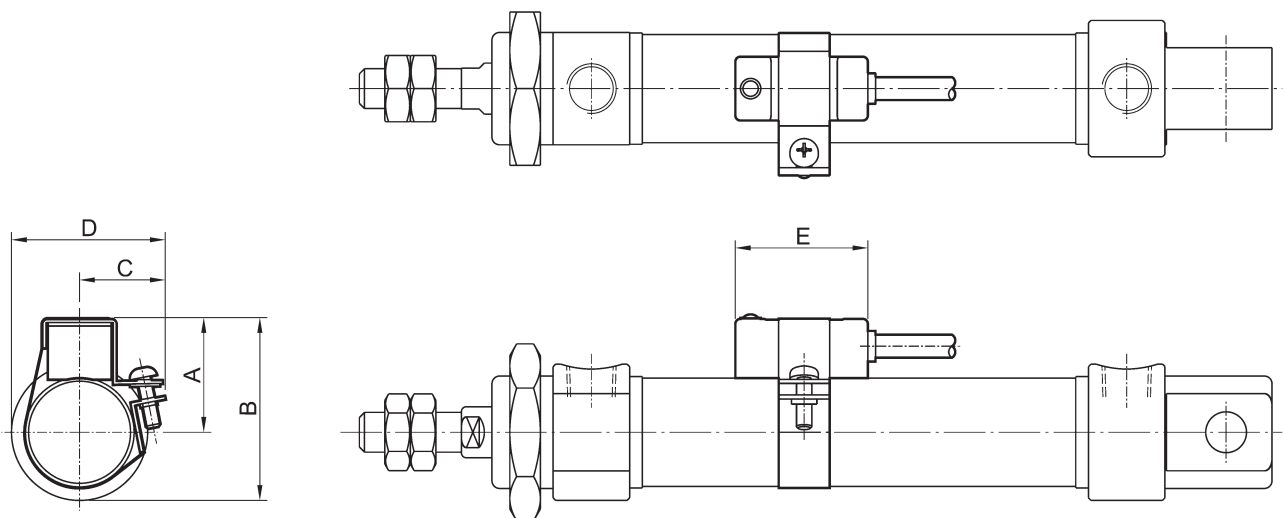

代號 Code 內徑 Tube I.D.	A	B	C	D	E
20	25	38.5	18	30.5	26
25	25.5	40.5	18.5	31.5	26
32	29	47	22	39	26
40	33	55.5	26	47	26

感應開關安裝 Installation of sensor switch $\Phi 16 \sim \Phi 40$

感應開關：RCM Sensor switch：RCM

感應開關束帶：BM** Sensor switch band：BM**

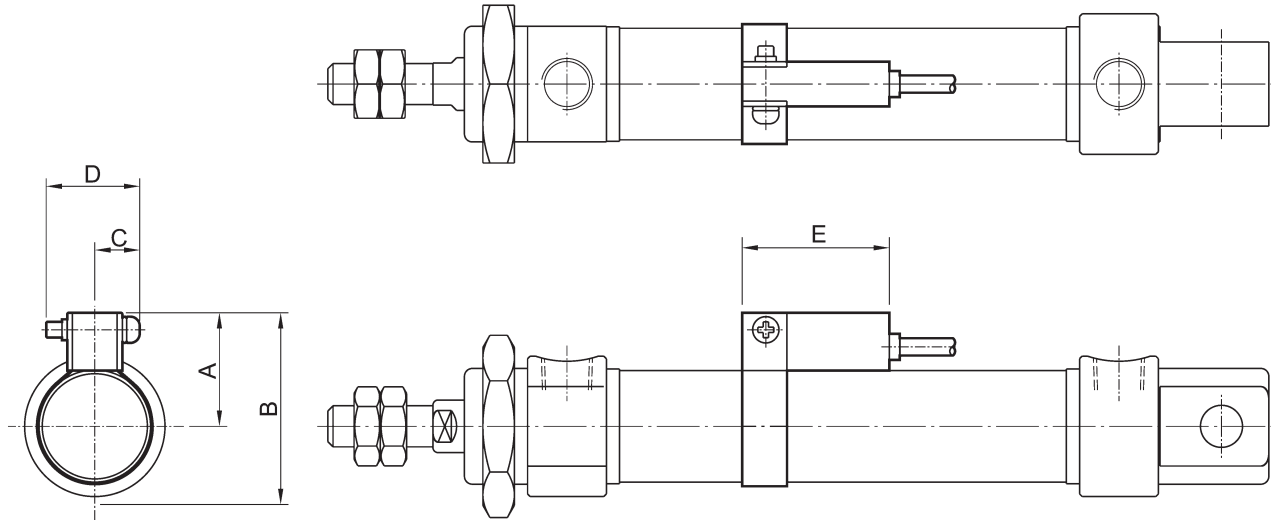

代號 Code 內徑 Tube I.D.	A	B	C	D	E
16	20	30	10	16	28
20	22	36	10	16	28
25	25	40	10	16	28
32	28	46	10	16	28
40	32	55	10	16	28

感應開關：RCS Sensor switch：RCS

感應開關束帶：BJ 16 Sensor switch band：BJ 16

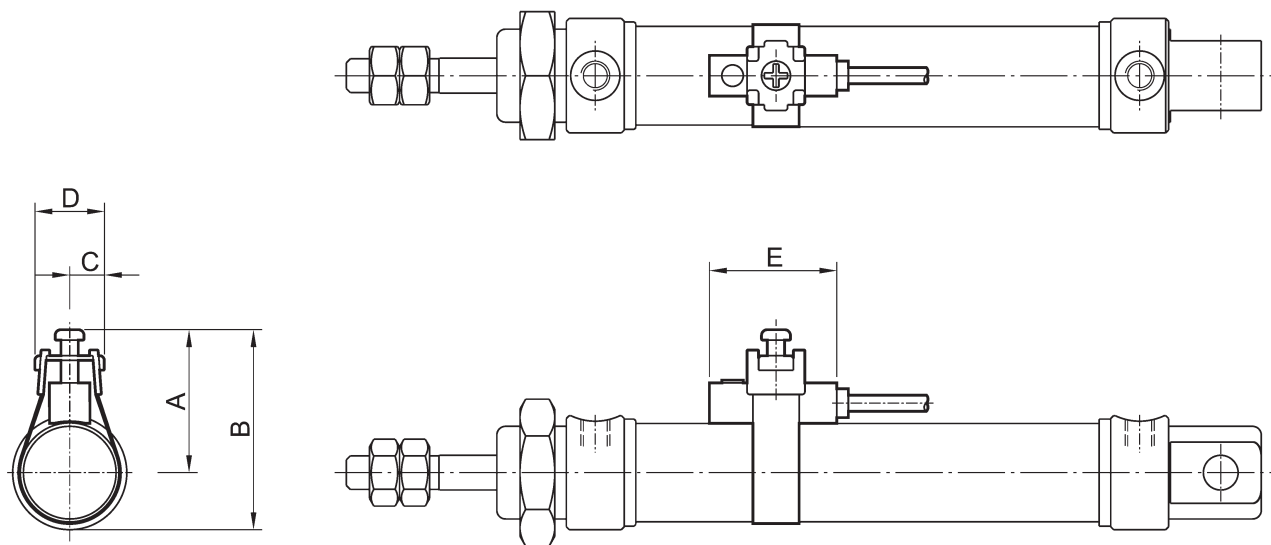

代號 Code 內徑 Tube I.D.	A	B	C	D	E
16	23.4	33.3	6	12	22

複動型 / 無尾型外觀尺寸 Dimensions / Double acting $\Phi 16 \sim \Phi 40$

N

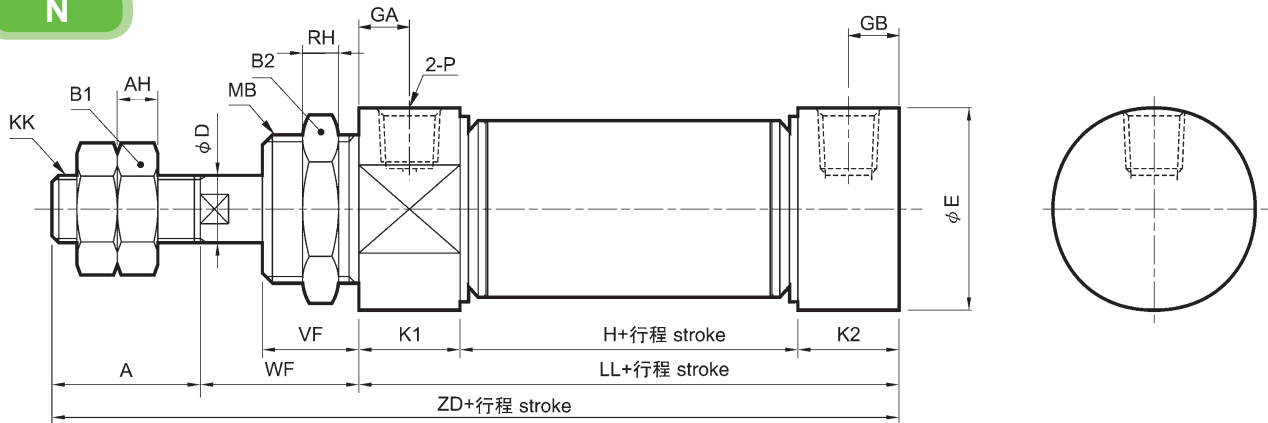

代號 Code 內徑 Tube I.D.	A	AH	B1	B2	D	E	GA	GB	H	KK	K1	K2	LL	MB	P	RH	VF	WF	ZD
16	16	5	10	22	6	19.7	5	5	34	M6 × 1.0	10	10	54	M16 × 1.5	M5 × 0.8	6	12	22	92
20	20	5	13	30	8	26.7	7.5	7.5	40	M8 × 1.25	15	15	70	M22 × 1.5	PT 1/8	6	12	18	108
25	22	6	17	30	10	29.7	7.5	7.5	40	M10 × 1.25	15	15	70	M22 × 1.5	PT 1/8	6	15	27	119
32	22	6	17	32	12	36	7.5	10.5	37	M10 × 1.25	15	18	70	M24 × 2.0	PT 1/8	8	18	30	122
40	30	7	19	41	14	45	7.5	10.5	42	M12 × 1.25	15	18	75	M30 × 2.0	PT 1/8	8	17	27	132

安裝配件 Mounting accessories

LB

LB- $\Phi 16$

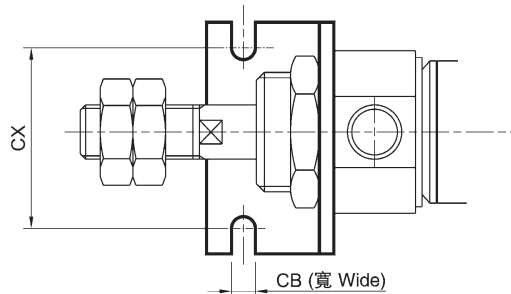

LB- $\Phi 20 \sim \Phi 40$

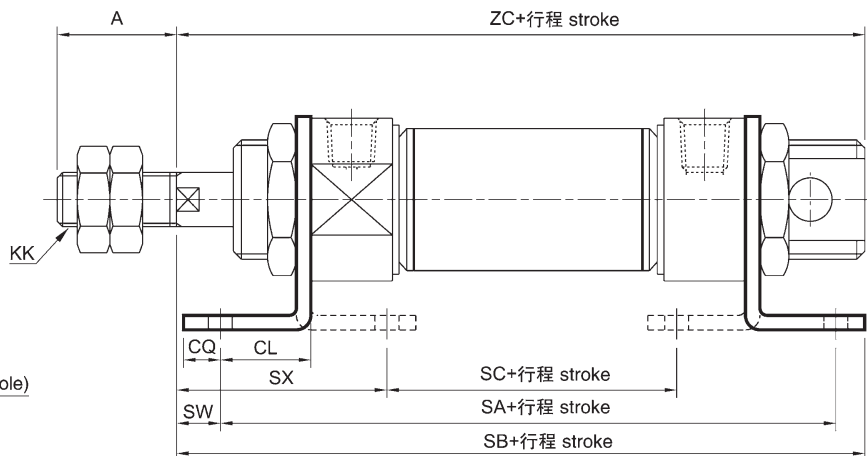
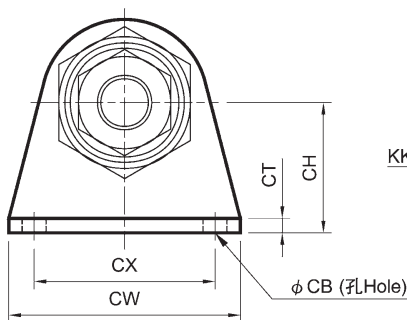

代號 Code 內徑 Tube I.D.	A	CB	CH	CL	CQ	CT	CW	CX	KK	SA	SB	SC	SW	SX	ZC
16	16	5.5	20	13	6	3.2	44	32	M6 × 1.0	80	95	34.4	9	31.8	92
20	20	6.6	25	15	8	3.2	54	40	M8 × 1.25	100	111	46.4	3	29.8	109
25	22	6.6	25	15	8	3.2	54	40	M10 × 1.25	100	120	46.4	12	38.8	118
32	22	6.6	32	25	8	4	59	45	M10 × 1.25	120	133	28	5	51	124
40	30	6.6	36	25	8	4	64	50	M12 × 1.25	125	135	33	2	48	130

複動型 / 安裝配件 Mounting accessories / Double acting $\Phi 16 \sim \Phi 40$

FA(FB)

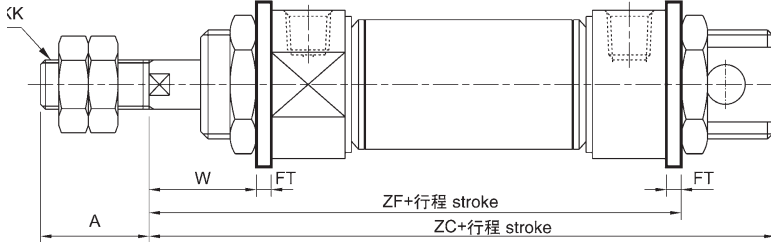

代號 Code 內徑 Tube I.D.	A	FB	FE	FF	FP	FR	FT	KK	W	ZC	ZF
16	16	5.5	26	52	40		3.2	M6 × 1.0	18.8	92	79.2
20	20	6.6	38	64	50		4.5	M8 × 1.25	13.5	109	92.5
25	22	6.6	38	64	50		4.5	M10 × 1.25	22.5	118	101.5
32	22	6.6	47	72	58	33	4.5	M10 × 1.25	25.5	124	104.5
40	30	6.6	50	84	70	36	4.5	M12 × 1.25	22.5	130	105.5

FA- $\Phi 16$

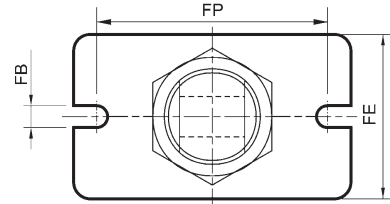

FA- $\Phi 20, \Phi 25$

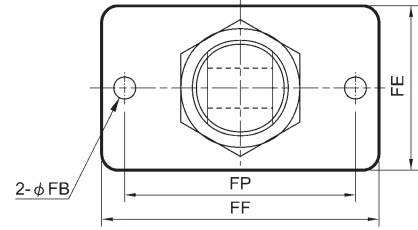

FA- $\Phi 32, \Phi 40$

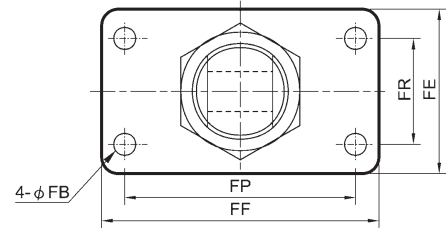

SDB

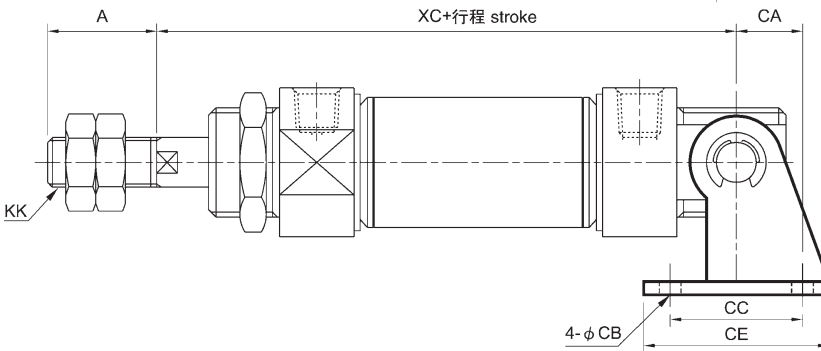
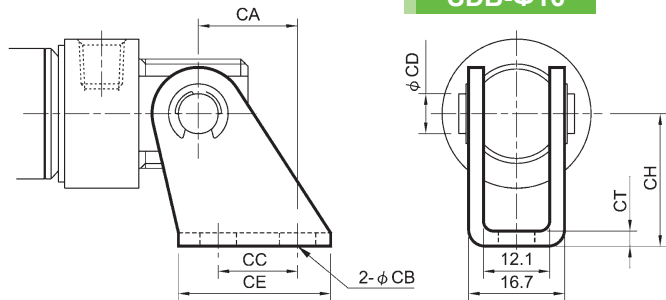

SDB- $\Phi 20 \sim \Phi 40$

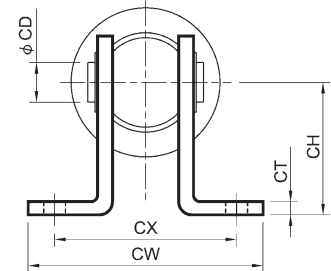

代號 Code 內徑 Tube I.D.	A	CA	CB	CC	CD	CE	CH	CT	CW	CX	KK	XC
16	16	15	5.5	12	6	23	20	2.3			M6 × 1.0	85
20	20	16	6.6	32	8	48	32	3.2	67	51	M8 × 1.25	100
25	22	16	6.6	32	8	48	32	3.2	67	51	M10 × 1.25	109
32	22	18	6.6	36	10	52	36	4	67	51	M10 × 1.25	114
40	30	20	6.6	40	12	56	40	4	69	53	M12 × 1.25	121

單動型 / 外觀尺寸 Dimensions / Single acting $\Phi 16 \sim \Phi 32$

15

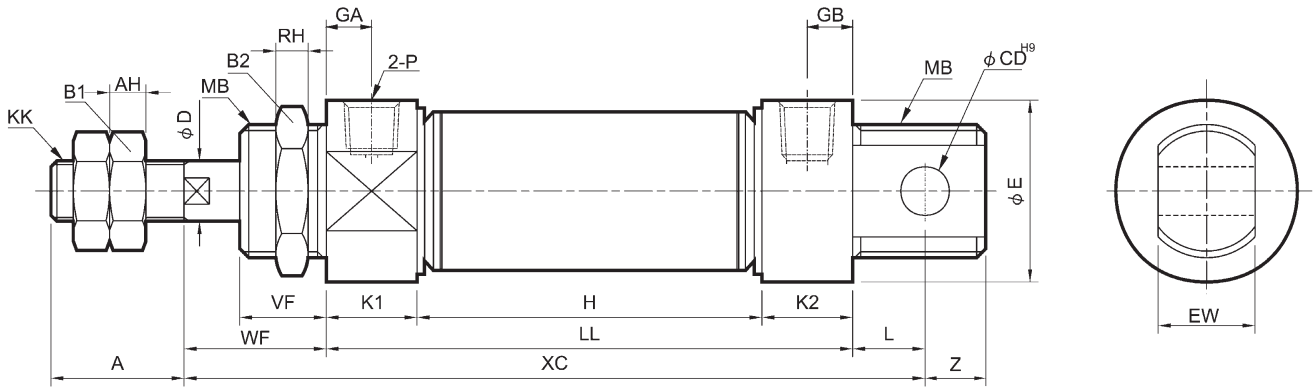

代號 Code 內徑 Tube I.D.	A	AH	B1	B2	CD	D	E	EW	GA	GB	KK	K1	K2	L	MB	P	RH	VF	WF	YP	Z
16	16	5	10	22	6	6	19.7	12 ^{-0.05} _{-0.4}	5	5	M6 × 1.0	10	10	9	M16 × 1.5	M5 × 0.8	6	12	22	5	7
20	20	5	13	30	8	8	26.7	16 ^{-0.05} _{-0.4}	7.5	7.5	M8 × 1.25	15	15	12	M22 × 1.5	PT 1/8	6	12	18	7.5	9
25	22	6	17	30	8	10	29.7	16 ^{-0.05} _{-0.4}	7.5	7.5	M10 × 1.25	15	15	12	M22 × 1.5	PT 1/8	6	15	27	7.5	9
32	22	6	17	32	10	12	36	16 ^{-0.05} _{-0.4}	7.5	10.5	M10 × 1.25	15	18	14	M24 × 2.0	PT 1/8	8	18	30	7.5	10

代號 Code 行程 Stroke 內徑 Tube I.D.	H							LL							XC						
	15	25	50	75	100	125	150	15	25	50	75	100	125	150	15	25	50	75	100	125	150
16	64	74	114	154	194	/	/	84	94	134	174	214	/	/	115	125	165	205	245	/	/
20	80	90	140	190	240	290	340	110	120	170	220	270	320	370	140	150	200	250	300	350	400
25	80	90	140	190	240	290	340	110	120	170	220	270	320	370	149	159	209	259	309	359	409
32	77	87	137	187	237	287	337	110	120	170	220	270	320	370	154	164	214	264	314	364	414

雙軸 Double Rod

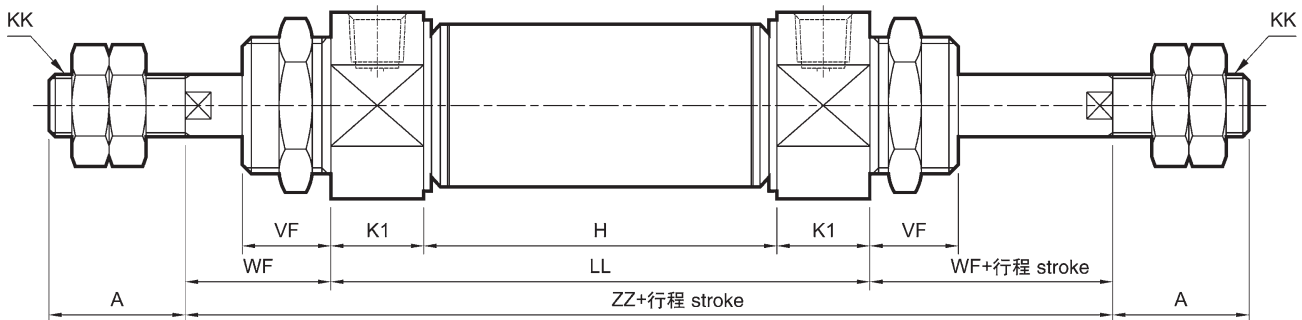

代號 Code 行程 Stroke 內徑 Tube I.D.	H							LL							ZZ						
	15	25	50	75	100	125	150	15	25	50	75	100	125	150	15	25	50	75	100	125	150
16	64	74	114	154	194	/	/	84	94	134	174	214	/	/	125	135	175	215	255	/	/
20	80	90	140	190	240	290	340	110	120	170	220	270	320	370	146	156	206	256	306	356	406
25	80	90	140	190	240	290	340	110	120	170	220	270	320	370	164	174	224	274	324	374	424
32	77	87	137	187	237	287	337	107	117	167	217	267	317	367	167	177	227	277	327	377	427

單動型 / 安裝配件 Mounting accessories / Single acting $\Phi 16 \sim \Phi 32$

FA(FB)

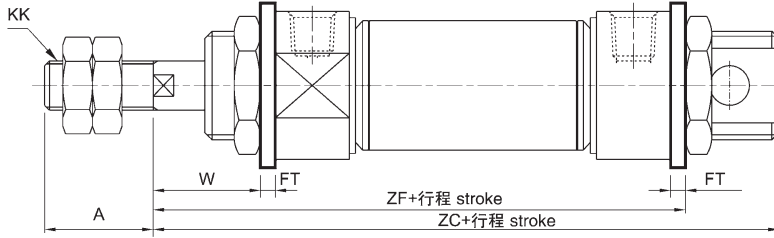

代號 Code 內徑 Tube I.D.	A	FB	FE	FF	FP	FR	FT	KK	W
16	16	5.5	26	52	40		3.2	M6 × 1.0	18.8
20	20	6.6	38	64	50		4.5	M8 × 1.25	13.5
25	22	6.6	38	64	50		4.5	M10 × 1.25	22.5
32	22	6.6	47	72	58	33	4.5	M10 × 1.25	25.5

代號 Code 行程 Stroke 內徑 Tube I.D.	ZC						ZF							
	15	25	50	75	100	125	150	15	25	50	75	100	125	150
16	121	131	171	211	251			109.2	119.2	159.2	199.2	239.2		
20	146	156	206	256	306	356	406	132.5	142.5	192.5	242.5	292.5	342.5	392.5
25	155	165	215	265	315	365	415	141.5	151.5	201.5	251.5	301.5	351.5	401.5
32	162	172	222	272	322	372	422	144.5	154.5	204.5	254.5	304.5	354.5	404.5

FA- $\Phi 16$

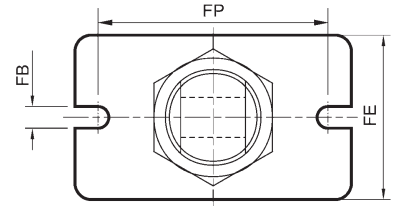

FA- $\Phi 20, \Phi 25$

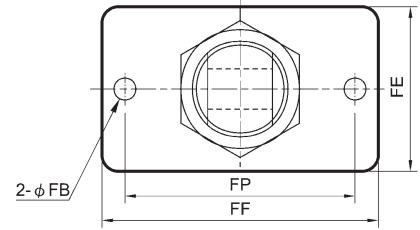

FA- $\Phi 32$

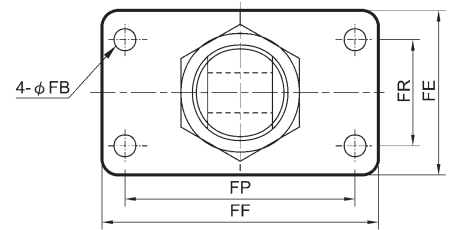

SDB

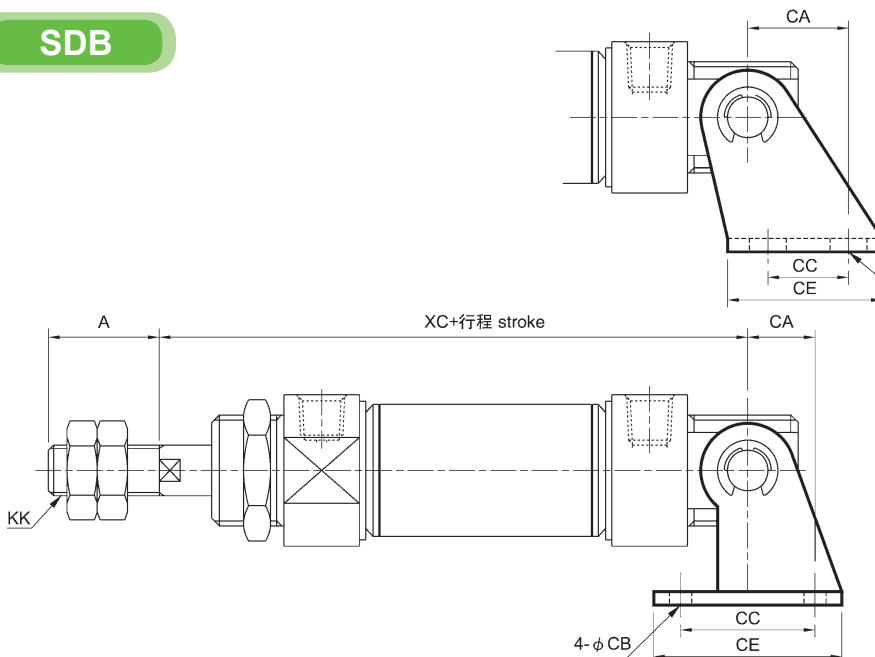

SDB- $\Phi 16$

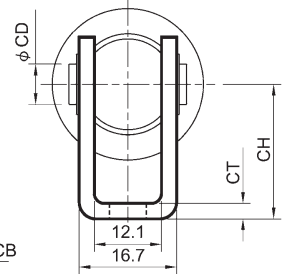

SDB- $\Phi 20 \sim \Phi 32$

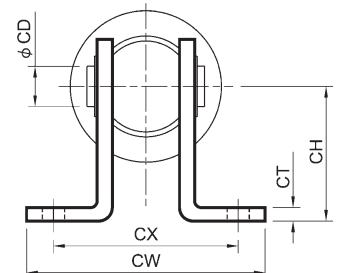

代號 Code 內徑 Tube I.D.	A	CA	CB	CC	CD	CE	CH	CT	CX	CW	KK
16	16	15	5.5	12	6	23	20	2.3			M6 × 1.0
20	20	16	6.6	32	8	48	32	3.2	51	67	M8 × 1.25
25	22	16	6.6	32	8	48	32	3.2	51	67	M10 × 1.25
32	22	18	6.6	36	10	52	36	4	51	67	M10 × 1.25

代號 Code 行程 Stroke 內徑 Tube I.D.	XC						
	15	25	50	75	100	125	150
16	107	117	157	197	257		
20	139	149	199	249	299	349	399
25	141	151	172	222	272	322	372
32	142	152	173	223	273	323	373

單動型 / 安裝配件 Mounting accessories / Single acting $\Phi 16 \sim \Phi 32$

LB

LB- $\Phi 16$

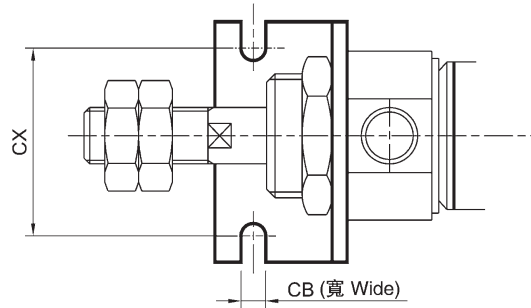

LB- $\Phi 20 \sim \Phi 40$

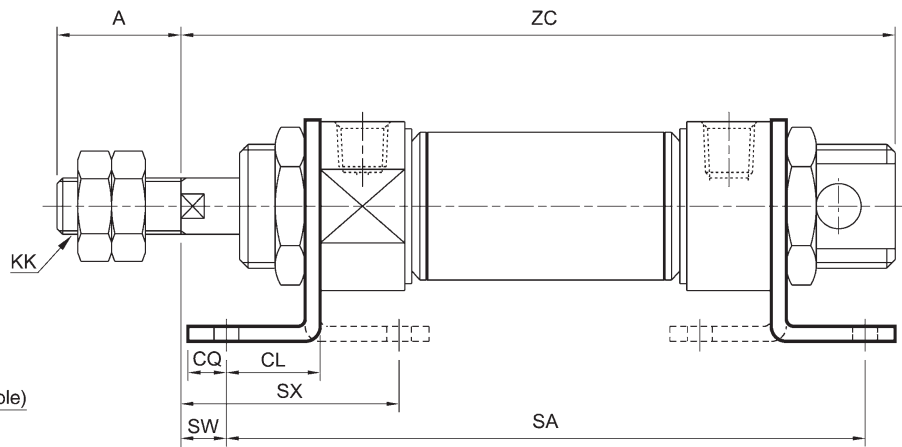
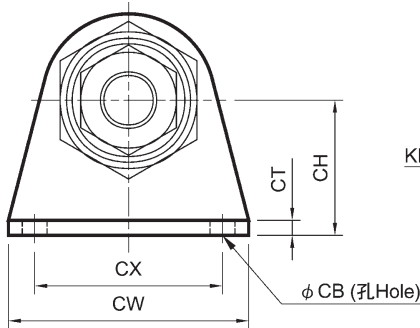

代號 Code 內徑 Tube I.D.	A	CB	CH	CL	CQ	CT	CW	CX	KK	SW	SX
16	16	5.5	20	13	6	3.2	44	32	M6 × 1.0	9	31.8
20	20	6.6	25	15	8	3.2	54	40	M8 × 1.25	3	29.8
25	22	6.6	25	15	8	3.2	54	40	M10 × 1.25	12	38.8
32	22	6.6	32	25	8	4	59	45	M10 × 1.25	5	51

代號 Code 行程 Stroke 內徑 Tube I.D.	SA							ZC						
	15	25	50	75	100	125	150	15	25	50	75	100	125	150
16	110	120	160	200	240			121	131	171	211	251		
20	140	150	200	250	300	350	400	146	156	206	256	306	356	406
25	140	150	200	250	300	350	400	155	165	215	265	315	365	415
32	160	170	220	270	320	370	420	162	172	222	272	322	372	422

Miniature Cylinders
迷你氣壓缸
FA

Y 接頭 Connector

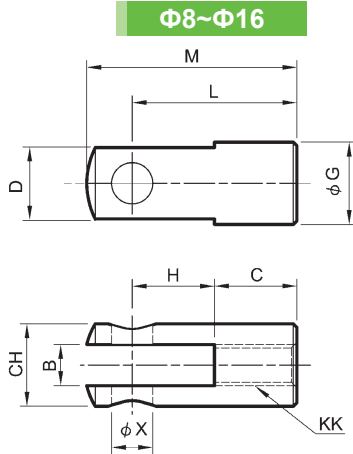

$\Phi 20 \sim \Phi 40$

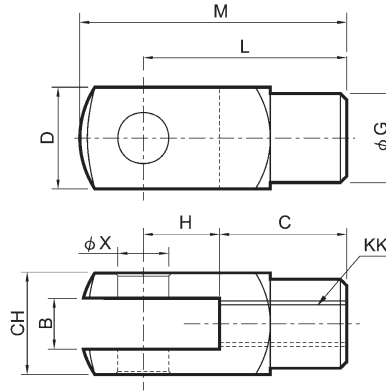

I 接頭 Connector

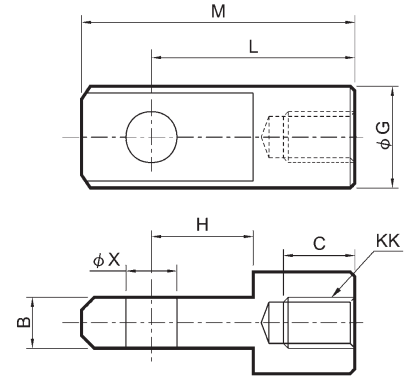

Y 型、I 型 接頭尺寸表 For Y、I connector

代號 Code 內徑 Tube I.D.	B		C		CH		D		G		H		KK		L		M		X ^{H9}	
	Y	I	Y	I	Y	I	Y	I	Y	I	Y	I	Y	I	Y	I	Y	I		
8, 10	4		8		8		8							M4 × 0.7		16		20.75		4 ^{+0.03 +0}
12, 16	6	6	12	8	12				12	12	12	10		M6 × 1		24	21	31	28	6 ^{+0.03 +0}
20	8	8	16	14	16			16		14	16	12		M8 × 1.25		32	32	42	42	8 ^{+0.036 +0}
25, 32	10	10	20	17	19			19		18	20	20	15	M10 × 1.25		40	40	52	52	10 ^{+0.036 +0}
40	12	12	24	21	22			22		20	24	24	18	M12 × 1.25		48	48	62	62	12 ^{+0.043 +0}

訂購代碼 Ordering Code

PIN - FA - 16 - Y - P

插銷 Pin

氣缸內徑
Tube I.D.

P: 含開口銷
P: with split pin

型號 Model

F1: $\Phi 8 \sim 12$ 內徑適用 For $\Phi 8 \sim 12$
Tube I.D.

FA: $\Phi 16 \sim 40$ 內徑適用 For $\Phi 16 \sim 40$
Tube I.D.

型式

Y: Y & I 接頭適用
SDB: SDB 配件適用
Type

Y: For Y & I connector
SDB: For SDB accessory

插銷 Pin

$\Phi 8 \sim \Phi 16$

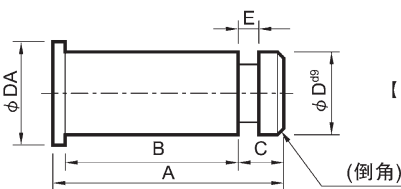

$\Phi 20 \sim \Phi 40$

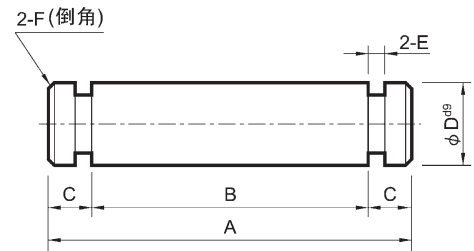
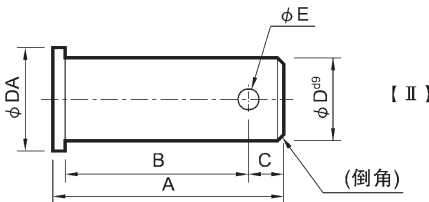

Y & I 型接頭用插銷尺寸表 For Y & I connector

代號 Code 內徑 Tube I.D.	A	B	C	D ^{d9}	DA	E	扣環開口銷 Split pin
8, 10	12	8.5	2	4 ^{-0.03 -0.06}	8	0.7	E3 (扣環)
12, 16	18.5	15	2	6 ^{-0.03 -0.06}	10	0.7	E4 (扣環)
20	24.5	20.5	2.5	8 ^{-0.04 -0.08}	12	ø2.5	2.5 × 16 長 L
25, 32	30	25	3.5	10 ^{-0.04 -0.08}	14	ø3.2	3.2 × 20 長 L
40	37	30	5	12 ^{-0.05 -0.09}	16	ø3.2	3.2 × 20 長 L

SDB 型裝配件用插銷尺寸表 For SDB

代號 Code 內徑 Tube I.D.	A	B	C	D ^{d9}	E	扣環 Split pin
8,10	18	14	2	4 ^{-0.03 -0.06}	0.7	E3.2
12	23.5	19.5	2	6 ^{-0.03 -0.06}	0.7	E5
16	21	17	2	6 ^{-0.03 -0.06}	0.7	E5
20, 25	30	25	2.5	8 ^{-0.04 -0.08}	0.9	E7
32	33	27	3	10 ^{-0.04 -0.08}	0.9	E9
40	37	31	3	12 ^{-0.05 -0.09}	0.9	E9