

Parallel Type Air Gripper FHZ2 Series $\phi 6 \sim \phi 40$

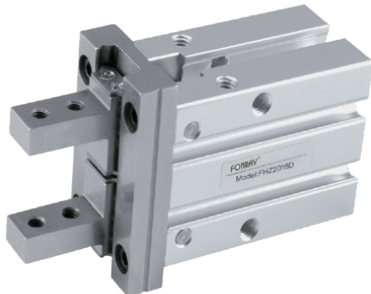

Advantages

- *Integral linear guide used for high rigidity.
- *Stainless steel to have great rust and wear resistance.
- *A positioning dowel pin hole is arranged at the bottom of the guide rail to prevent the guide rail deviating from the cylinder block.
- *High degree of mounting flexibility.
- *Finger positions can be selected.

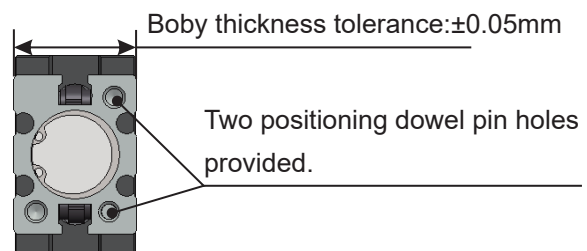

Using high quality stainless steel with good rust resistance as materials.
S company uses powder metallurgy as materials which is lowcost but has porosity.

Finger positions can be selected.

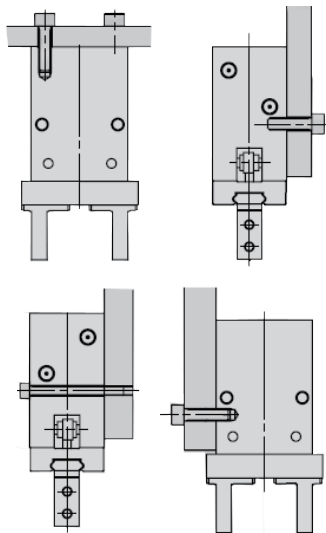
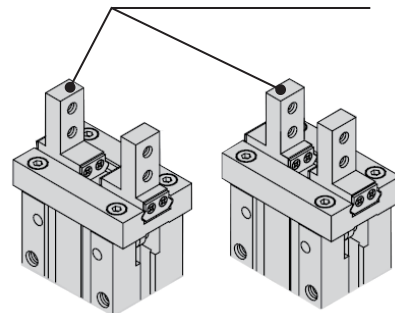

A positioning dowel pin hole is arranged at the bottom of the guide rail to prevent the guide rail deviating from the cylinder block.
(There is no dowel pin holes under 20φ bore size of S company from Japan).

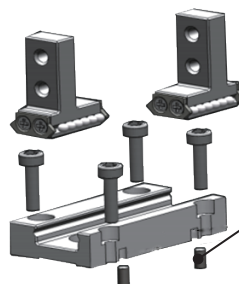

Narrow type
S company
from Japan

Wide type

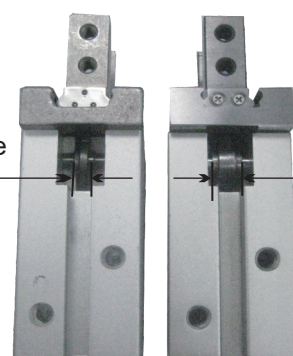

Parallel Type Air Gripper FHZ2 Series $\Phi 6 \sim \Phi 40$

Double acting

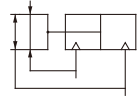

Specifications

Bore size	6 mm	10 mm	16 mm	20 mm	25 mm	32 mm	40 mm
Fluid	Air						
Operating pressure range	Double acting	0.15~0.7MPa	0.2~0.7MPa	0.1~0.7MPa		0.1~0.7MPa	
Ambient and fluid temperature	-10~60°C (with no condensation)						
Repeatability	± 0.01mm					± 0.02mm	
Max. operating frequency (c . p . m)	180					60	
Lubrication	No need						
Action	Double acting • Single acting						
Auto switch	Contactless auto switch						
Piping size	M3 x 0.5			M5 x 0.8			

How to Order

FHZ 2 — 16 D — M9B

Dust cover type

Nil	Standard type
J	With dust cover
L	Long stroke

Note) Only 16mm bore size cylinder has dust cover and long stroke version.

Auto switch

Nil	Without auto switch
M9B	with M9B
F8N	with F8N
T2H	with T2H

Note) wire length symbols:
1m..... Nil (Example) M9B
3m..... L (Example) M9BL

Number of auto switches

Nil	2pcs.
S	1pcs.

Action

D	Double acting
S	Single acting (Normally open)
C	Single acting (Normally closed)

Bore size

6	6 mm
10	10 mm
16	16 mm
20	20 mm
25	25 mm
32	32 mm
40	40 mm

(Dust cover is available)

Finger option

[Standard]	[Narrow type]
<p>Nil: Basic type</p>	<p>N: Basic type</p>
<p>1: Side tapped mounting</p>	<p>N1: Side tapped mounting</p>
<p>2: Through-holes</p>	<p>N2: Through-holes</p>
<p>3: Flat type</p>	

How to order1)

Need bore size 16mm and double acting wide finger.

Model No. FHZ2-16D

Note) Auto switch F8N for bore size 6φ.

Auto switch T2H for bore size 10φ.

Confirmation of External Force on Fingers

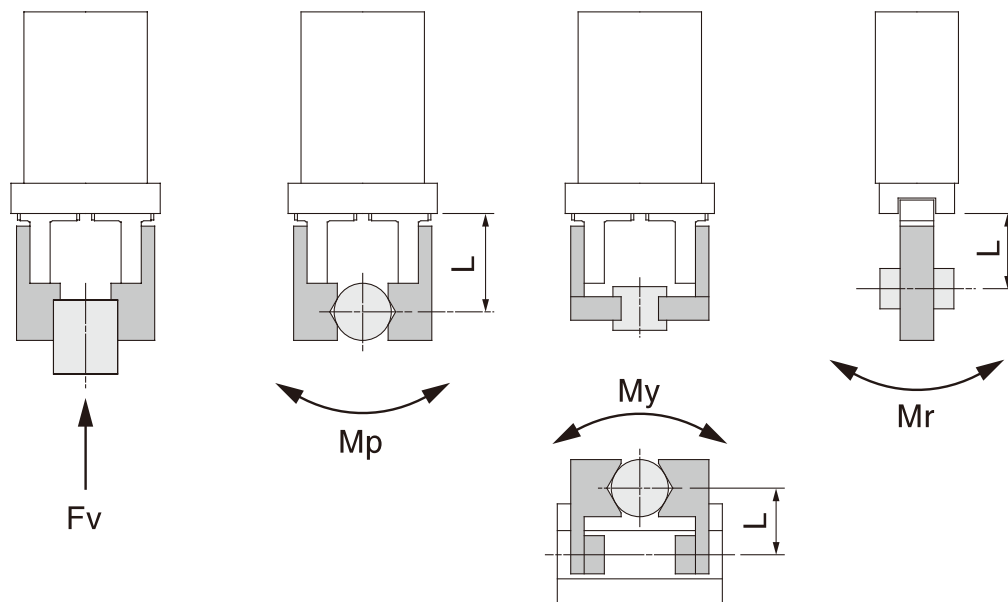

Model	Max. vertical load F_v (N)	Max. allowable moment		
		M_p (N·m)	M_y (N·m)	M_r (N·m)
FHZ2-6D	10	0.04	0.04	0.08
FHZ2-10D	58	0.26	0.26	0.53
FHZ2-16D	98	0.68	0.68	1.36
FHZ2-20D	147	1.32	1.32	2.65
FHZ2-25D	255	1.94	1.94	3.88
FHZ2-32D	343	3	3	6
FHZ2-40D	490	4.5	4.5	9

Note) Values for load and moment in the table indicate static values.

Calculation of allowable external force (when moment load is applied)	Calculation example(FHZ2-16D) 2-20D
$\text{Allowable load } F \text{ (N)} = \frac{\text{max. allowable moment } M}{L \times 10^{-3}}$ <p>(*: Constant for unit conversion)</p>	<p>When a static load of $f=10\text{N}$ is operating, which applies pitch moment to point $L=30\text{mm}$ from the FHZ2-16D guide. Therefore, it can be used</p> $\text{Allowable load } F = \frac{0.68}{30 \times 10^{-3}} = 22.7 \text{ (N)}$ <p>Load $f = 10 \text{ (N)} < 22.7 \text{ (N)}$</p> <p>Calculation example(FHZ2-16D)</p>

Model Selection Illustration

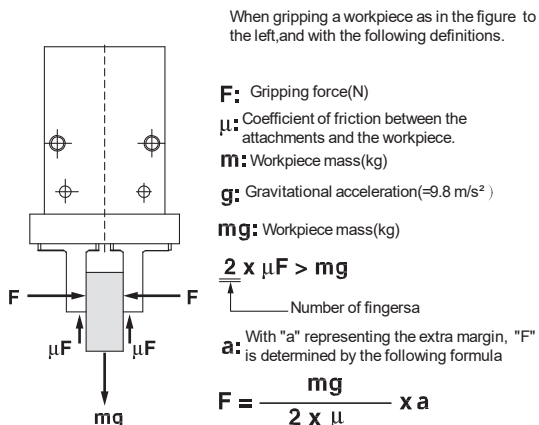

Model

Values based on pressure of 0.5MPa

Action	Model	Gripping force per finger effective value(N)		Opening/Closing stroke(Both sides) mm
		External	Internal	
Double acting	FHZ2-6D	3.3	6.1	4
	FHZ2-10D	11	17	4
	FHZ2-16D	34	45	6
	FHZ2-20D	42	66	10
	FHZ2-25D	65	104	14
	FHZ2-32D	158	193	22
	FHZ2-40D	254	318	30

Performance parameters under different pressures

External Gripping Force

The effective force shown in the graphs to the right, which is the thrust of one finger, when both fingers and attachments are in full contact with the workpiece as shown in the figure below.

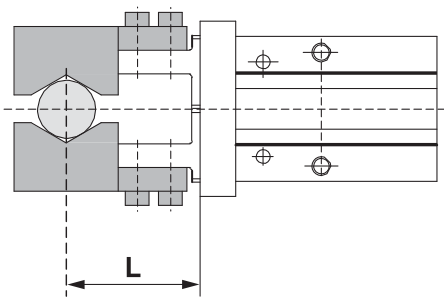

FHZ2-6D

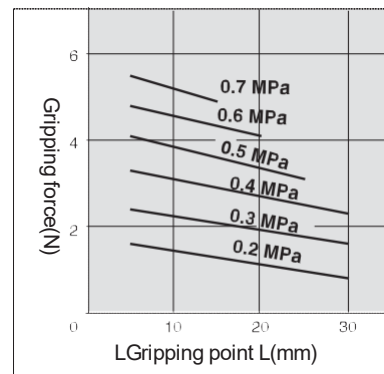

FHZ2-10D

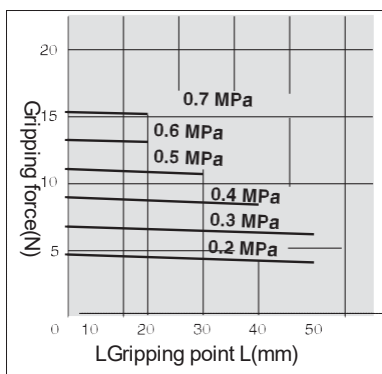

FHZ2-16D

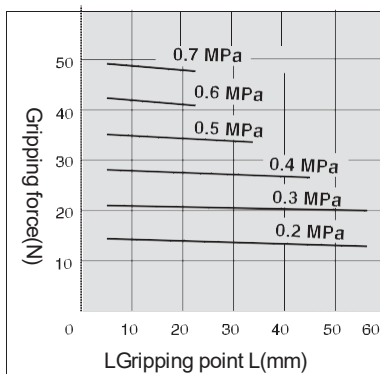

FHZ2-20D

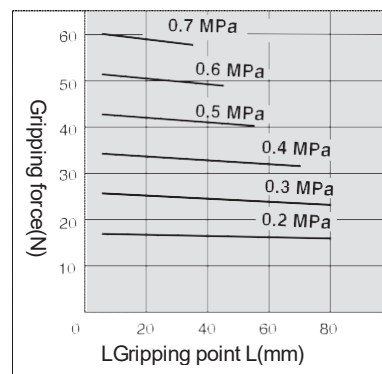

FHZ2-25D

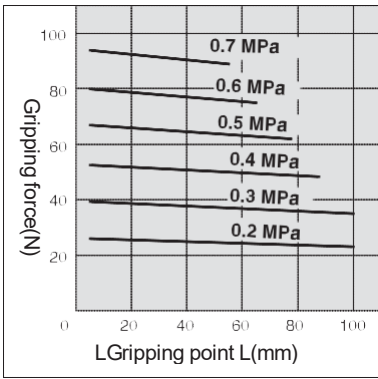

FHZ2-32D

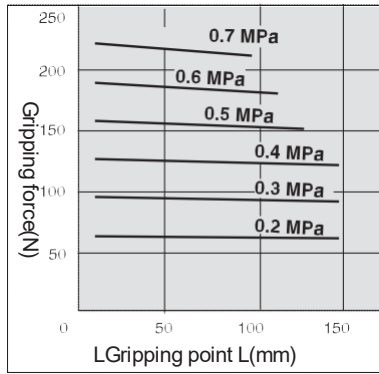

FHZ2-40D

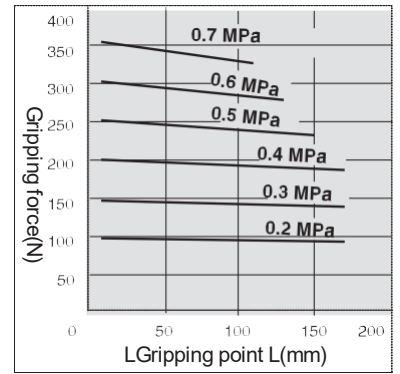

Internal Gripping Force

The effective force shown in the graphs to the right, which is the thrust of one finger, when both fingers and attachments are in full contact with the workpiece as shown in the figure below.

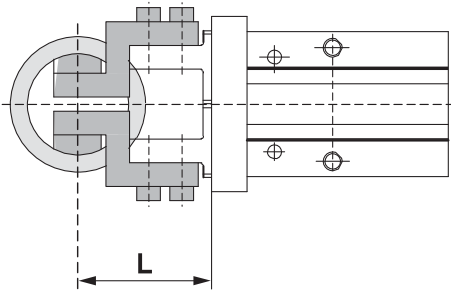

FHZ2-6D

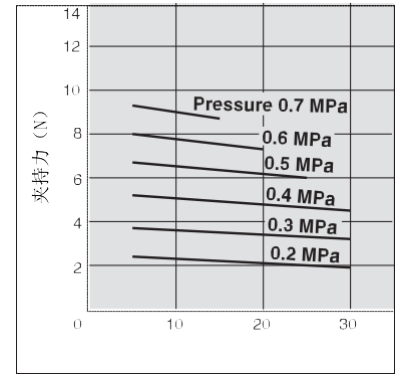

FHZ2-10D

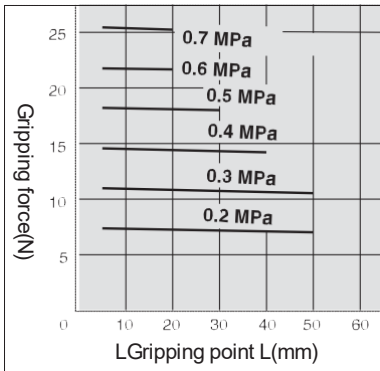

FHZ2-16D

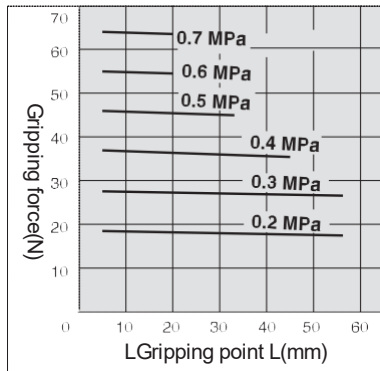

FHZ2-20D

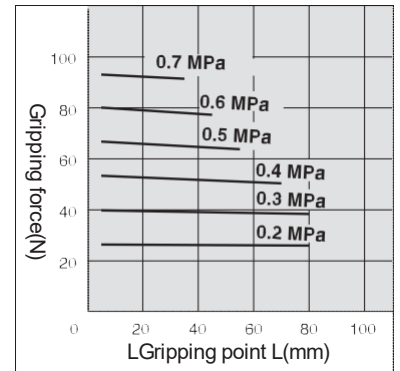

FHZ2-25D

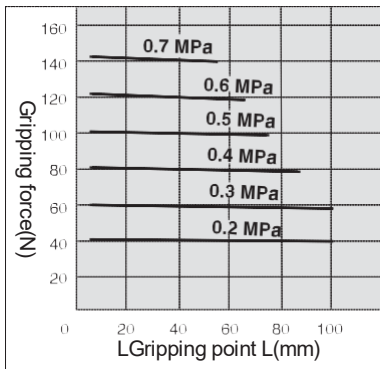

FHZ2-32D

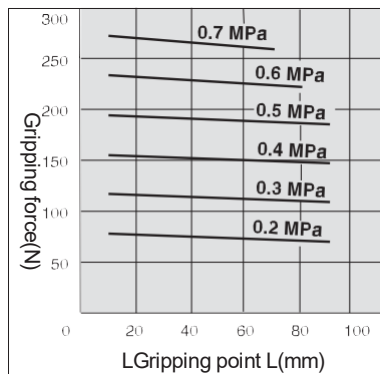

FHZ2-40D

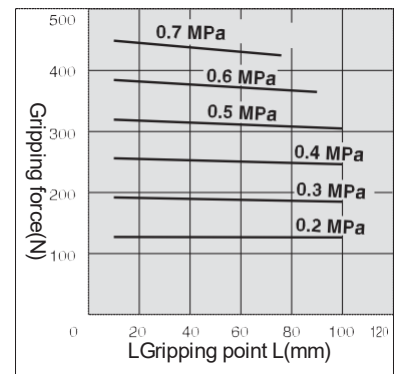

The air gripper should be operated so that the workpiece gripping point "L" and the amount of overhang "H" stay within the range shown for each operating pressure given in the graphs to the right. If the workpiece gripping point goes beyond the range limits, this will have an adverse effect on the life of the air gripper.

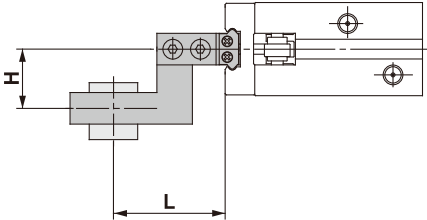

External Grip FHZ2-6D

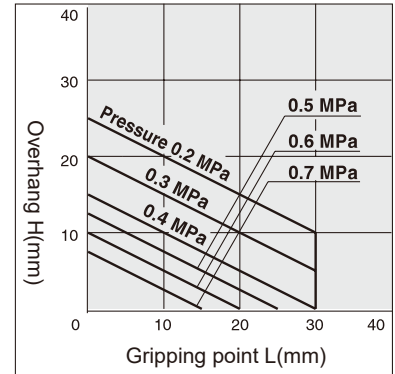

FHZ2-10D

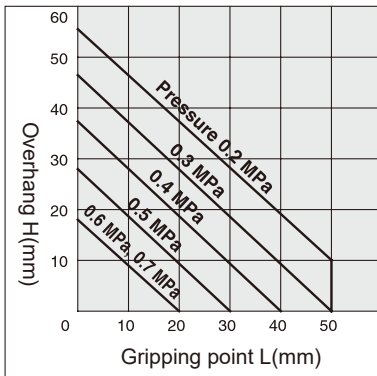

FHZ2-16D

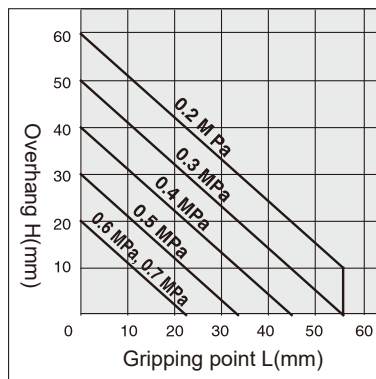

FHZ2-20D

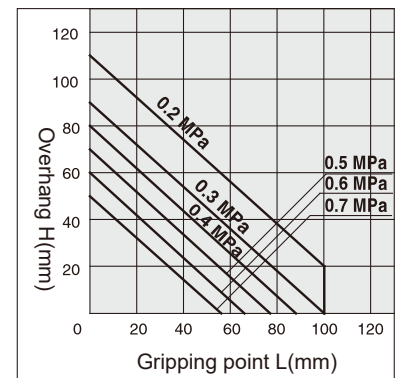

FHZ2-25D

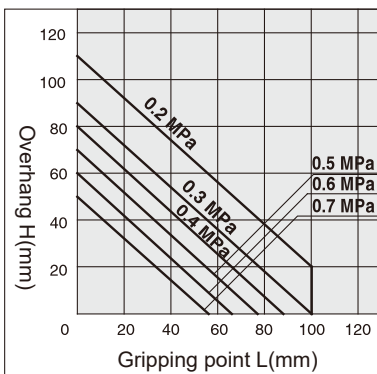

FHZ2-32D

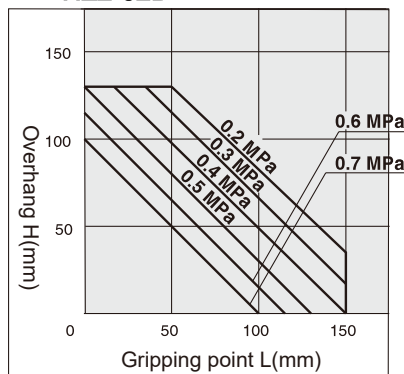

FHZ2-40D

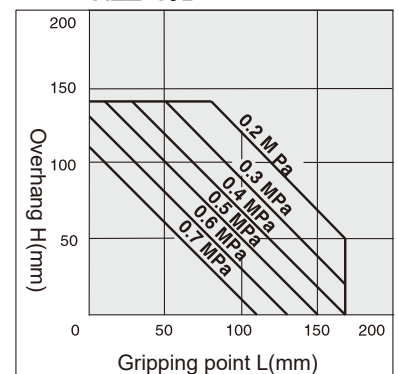

The air gripper should be operated so that the workpiece gripping point "L" and the amount of overhang "H" stay within the range shown for each operating pressure given in the graphs to the right. If the workpiece gripping point goes beyond the range limits, this will have an adverse effect on the life of the air gripper.

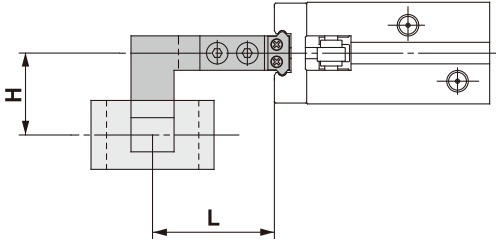

Internal Grip FHZ2-6D

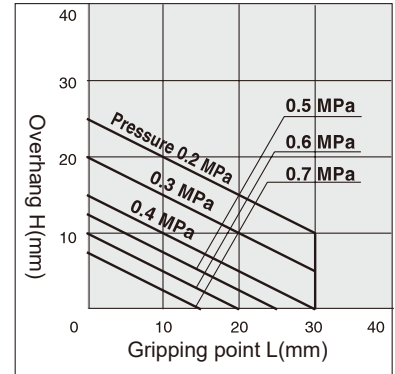

FHZ2-10D

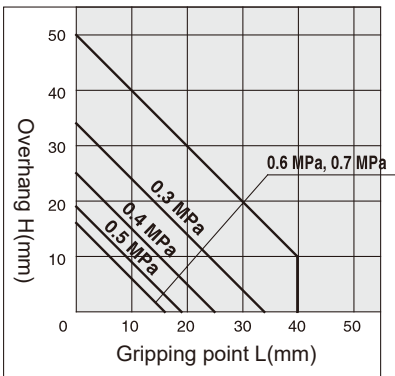

FHZ2-16D

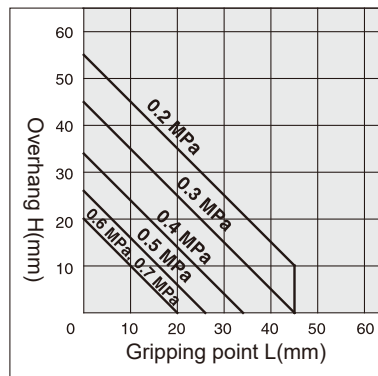

FHZ2-20D

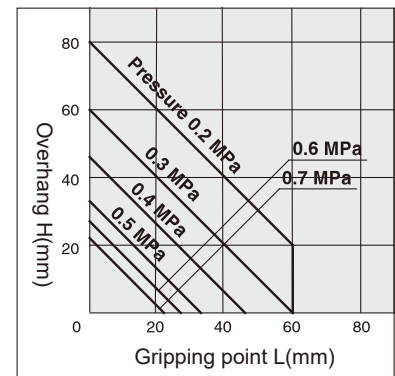

FHZ2-25D

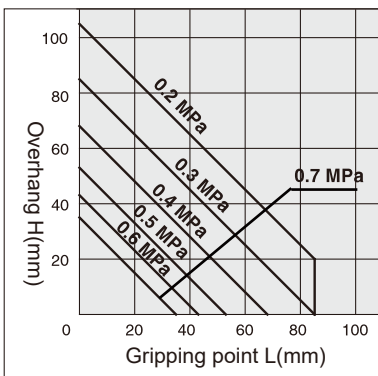

FHZ2-32D

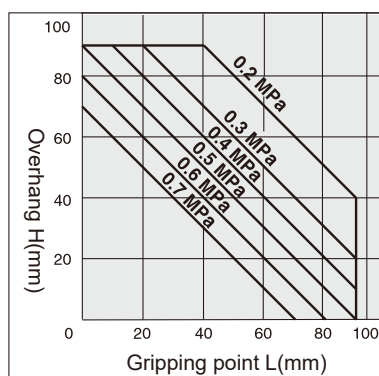

FHZ2-40D

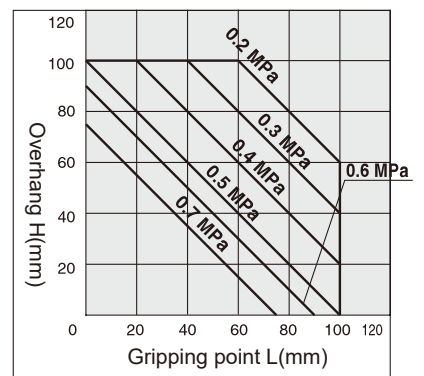

Outline drawing(mm)
Standard Type
FHZ2-6D
Double acting

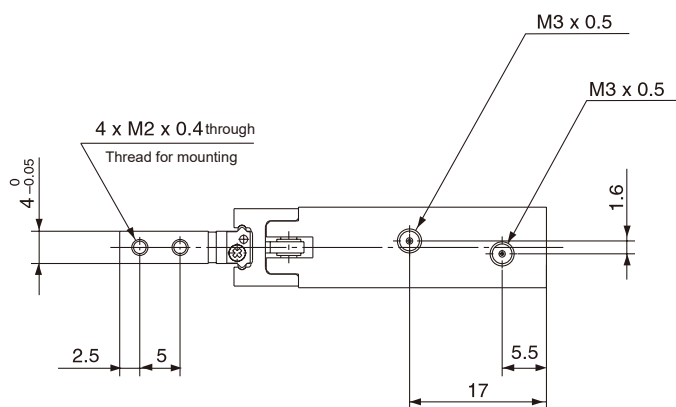
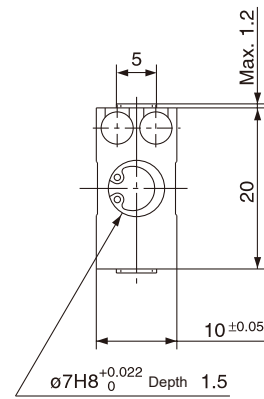
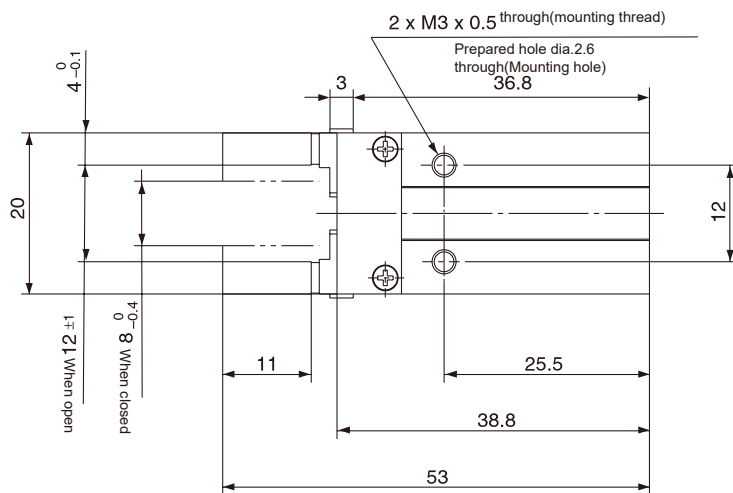
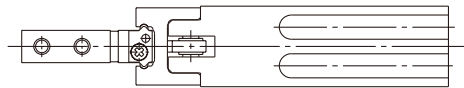

Auto switch mounting groove dimensions

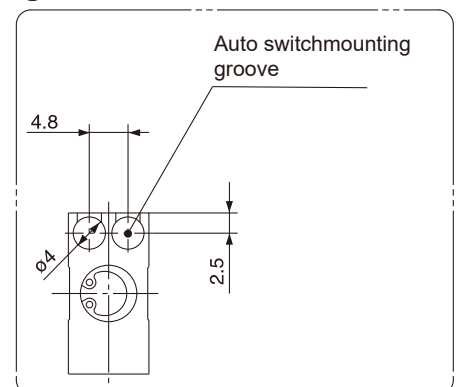

Outline drawing(mm)
Standard Type
FHZ2-10
DDouble acting

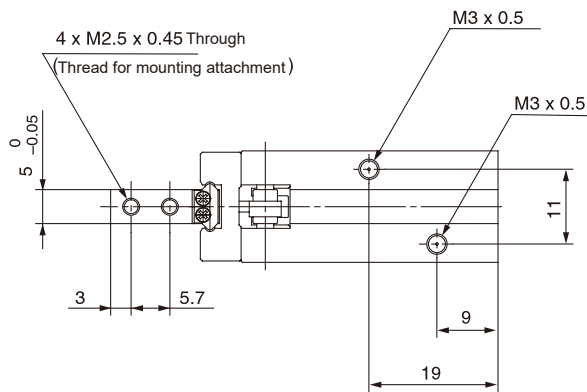
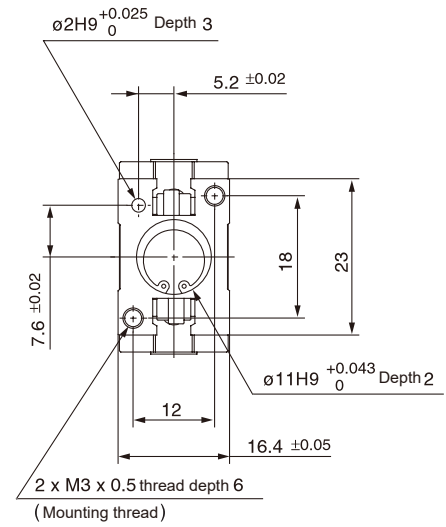
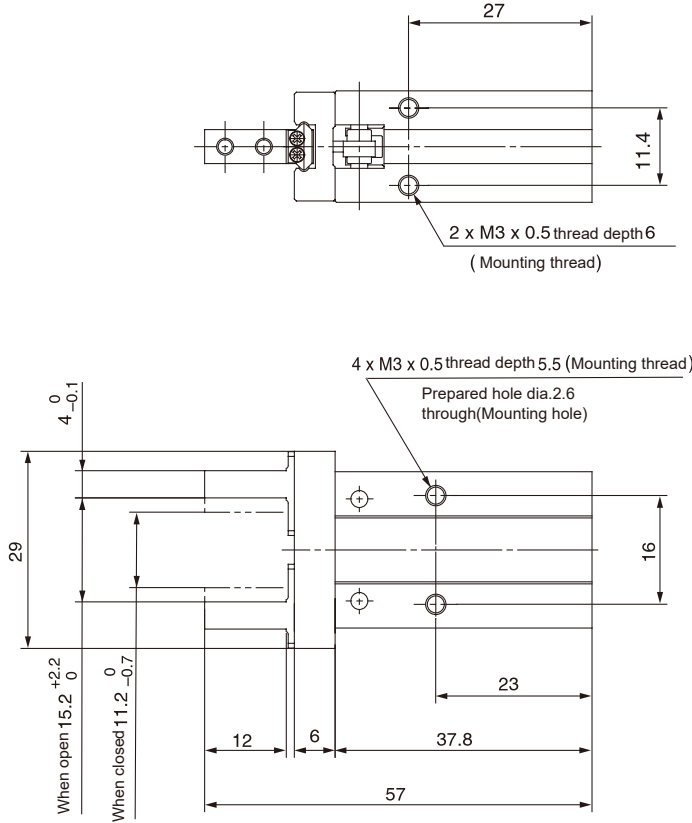

Auto switch mounting groove dimensions

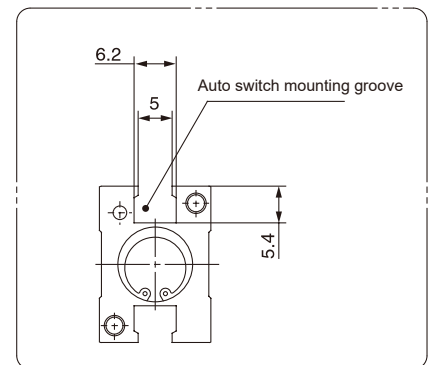

Flat Type Fingers

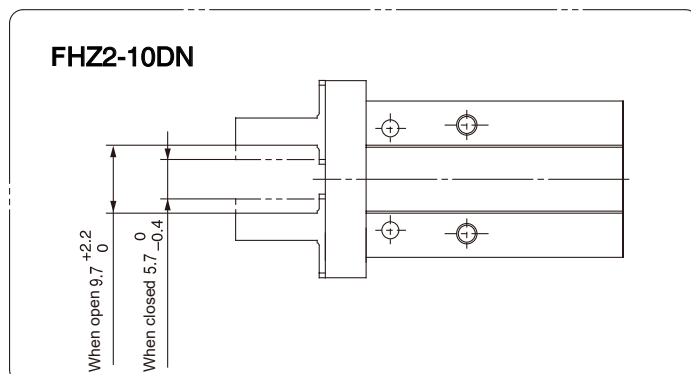

Outline drawing(mm)
Standard Type
FHZ2-16D
DDouble acting

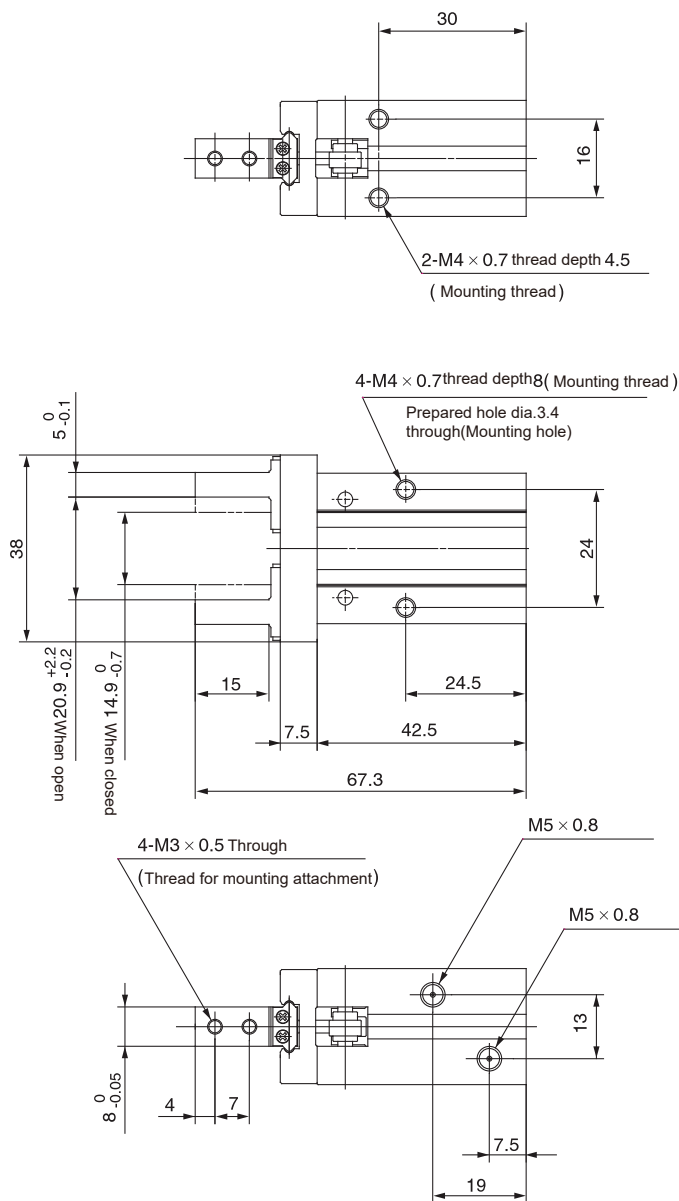

Auto switch mounting groove dimensions

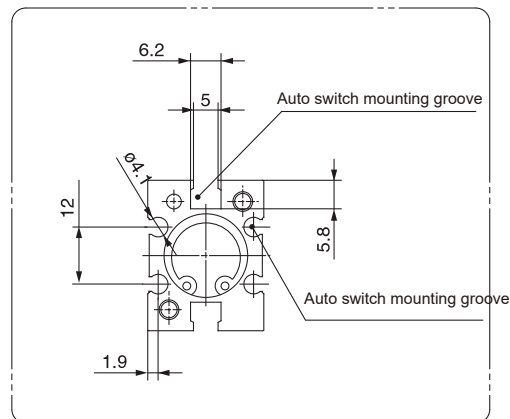

Flat Type Fingers

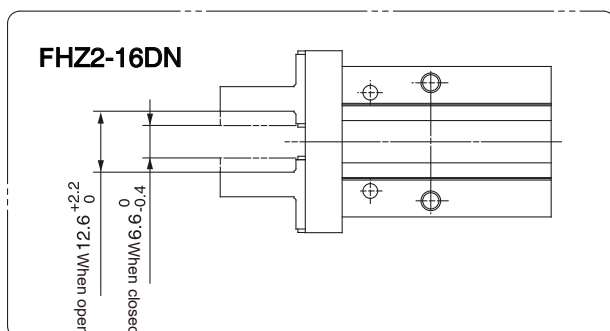

Outline drawing(mm)
Standard Type
FHZ2-20D
DDouble acting

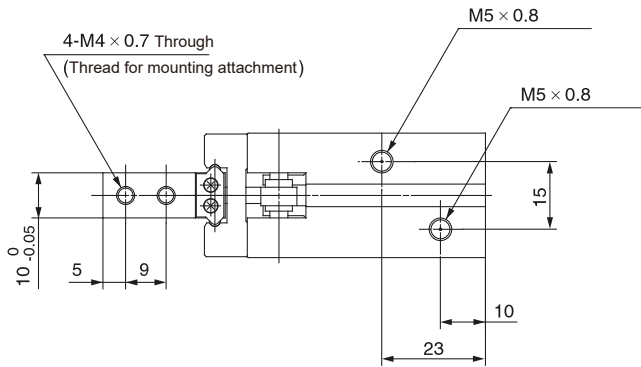
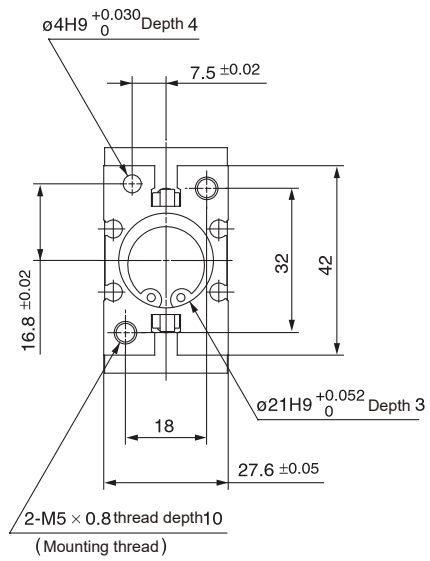
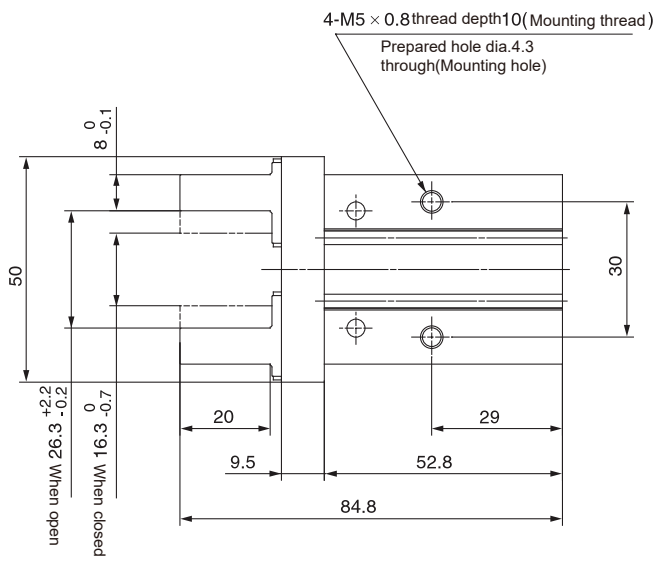
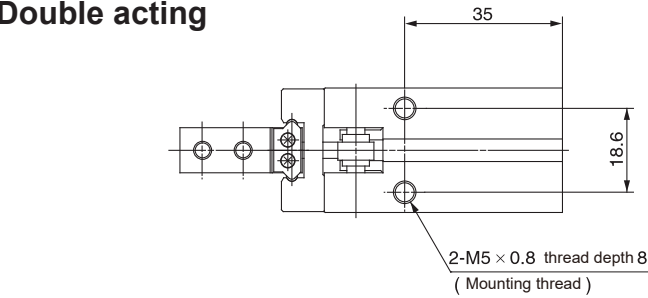

Auto switch mounting groove dimensions

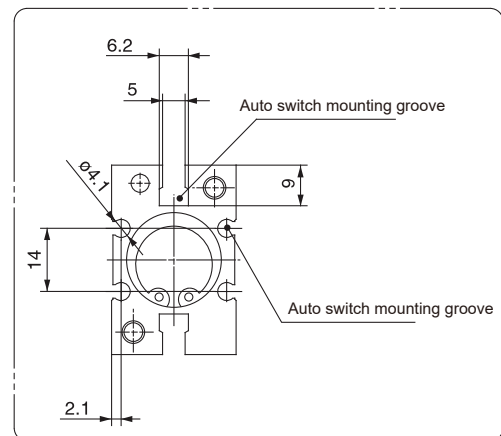

Flat Type Fingers

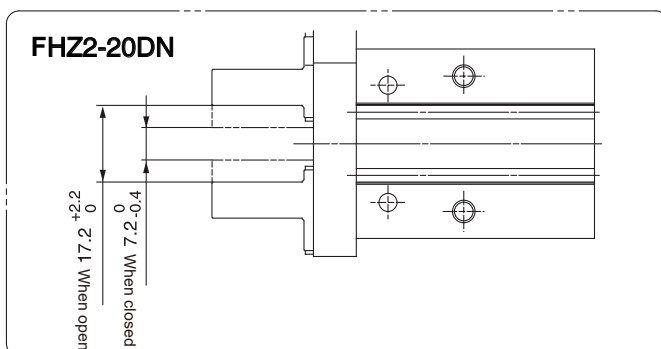

Outline drawing(mm)
Standard Type
FHZ2-25D
DDouble acting

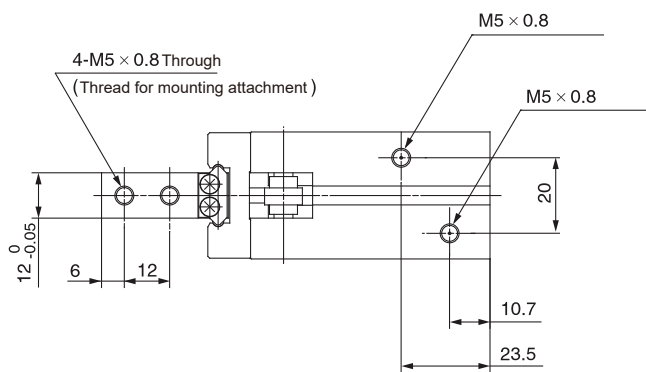
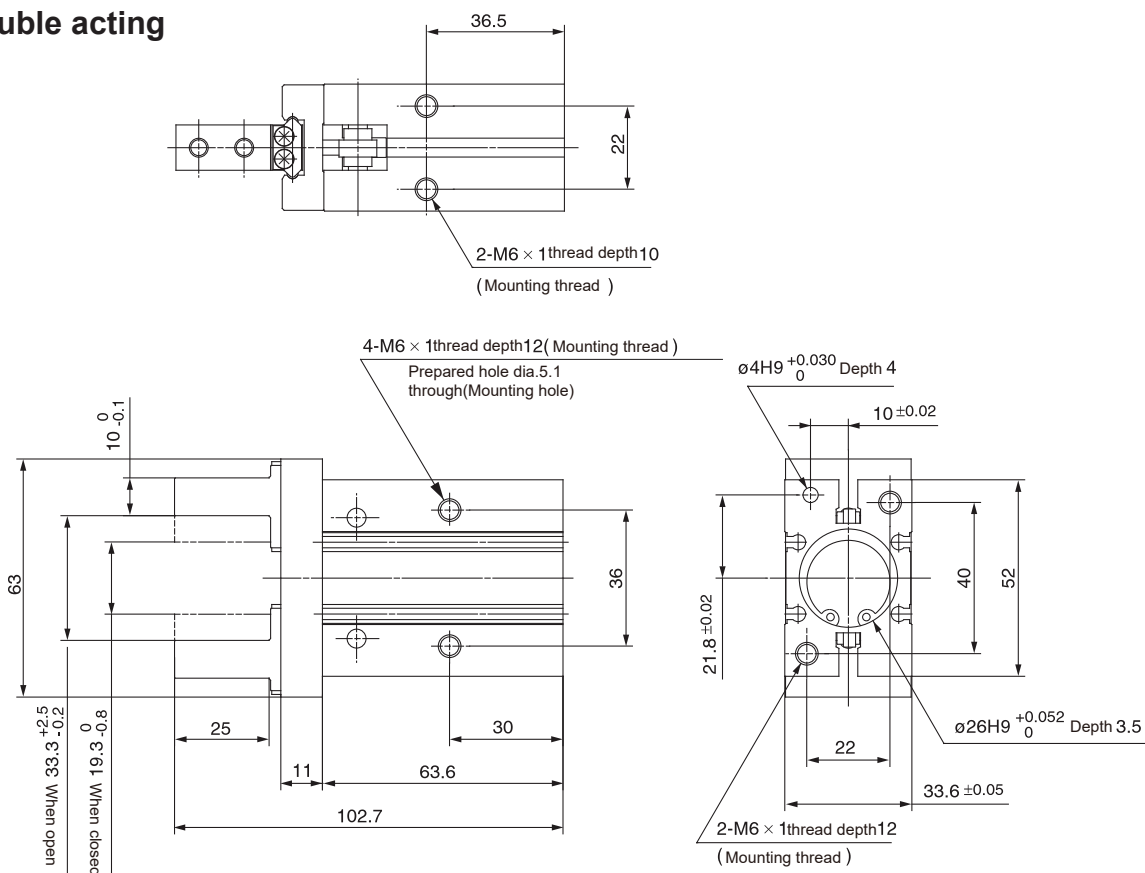

Auto switch mounting groove dimensions

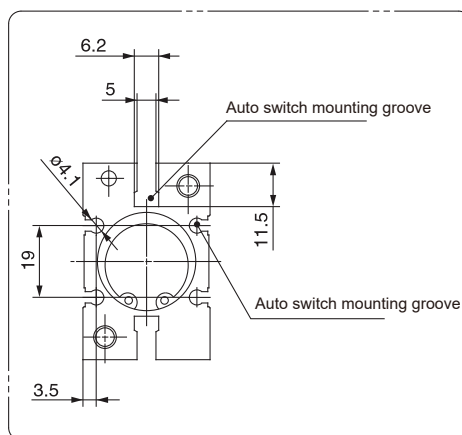

Flat Type Fingers

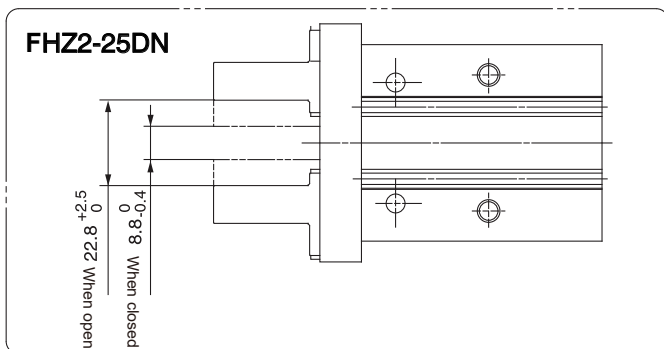

Outline drawing(mm)
Standard Type
FHZ2-32D
Double acting

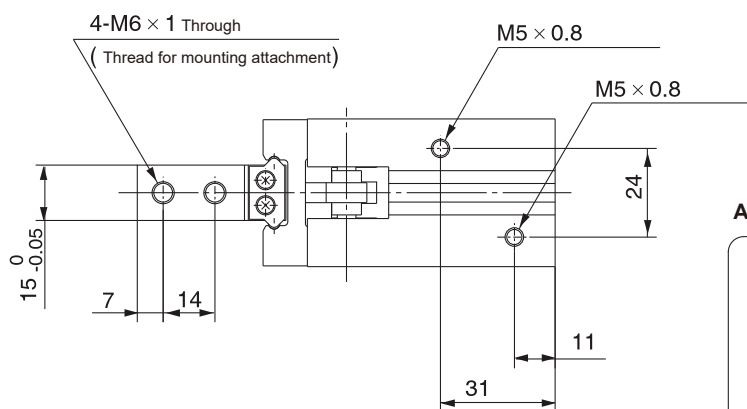
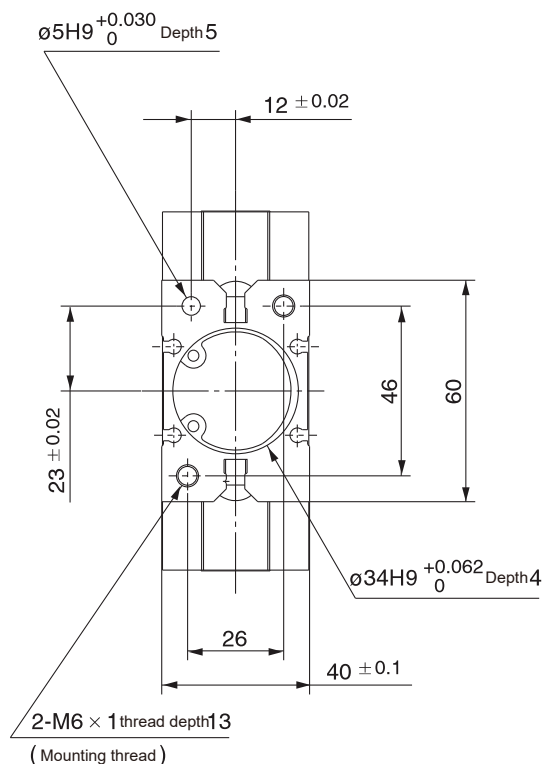
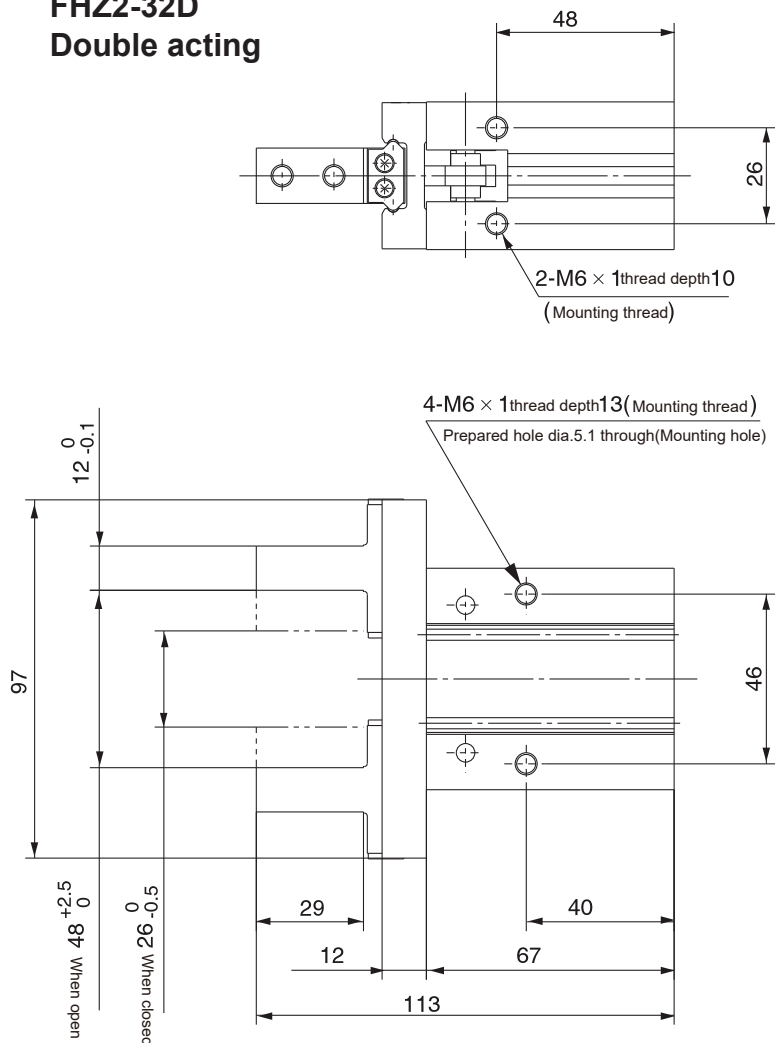

Auto switch mounting groove dimensions

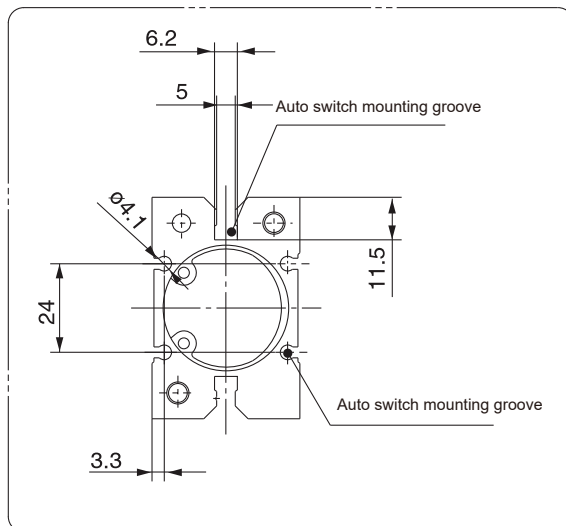

Outline drawing(mm)
Standard Type
FHZ2-40D
Double acting

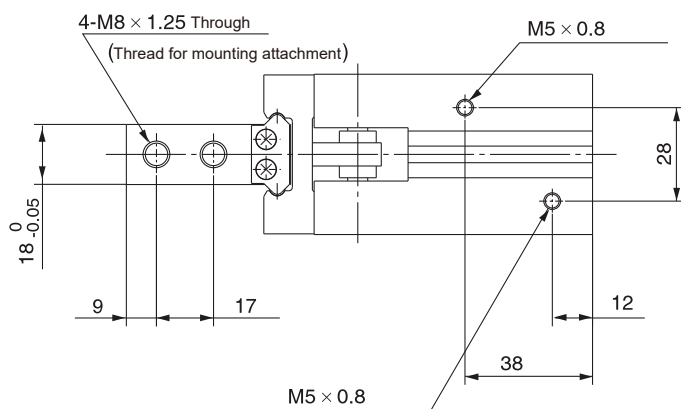
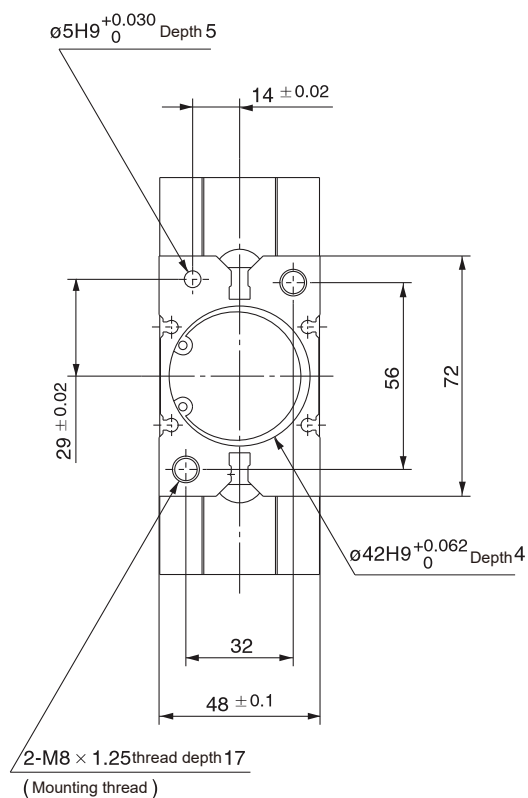
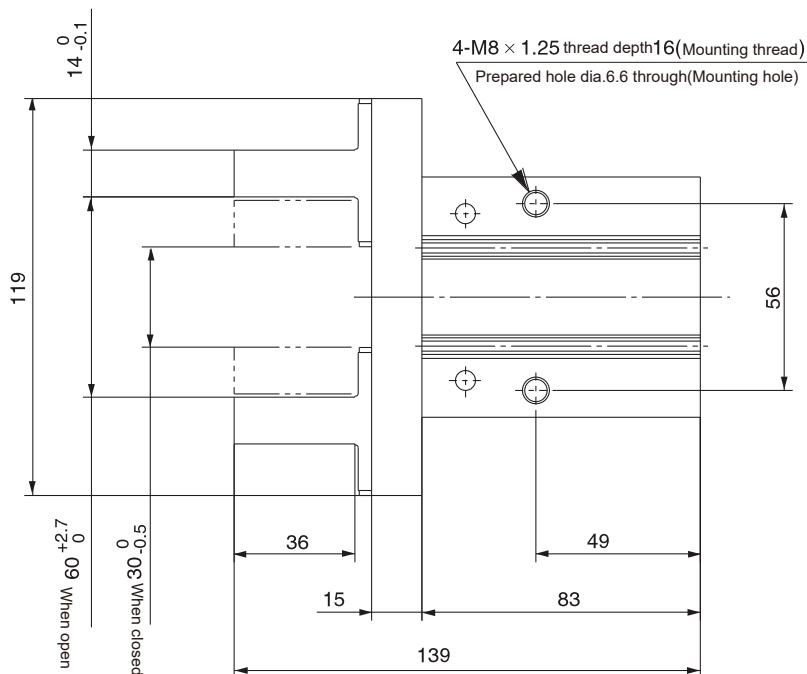
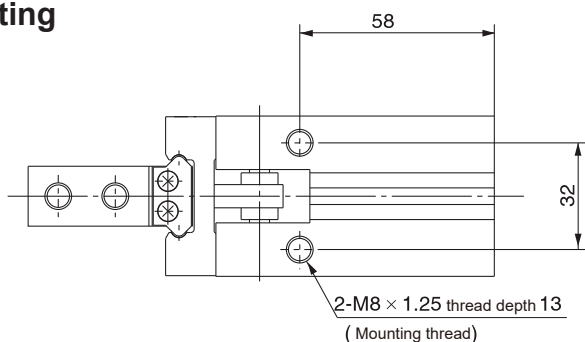

Auto switch mounting groove dimensions

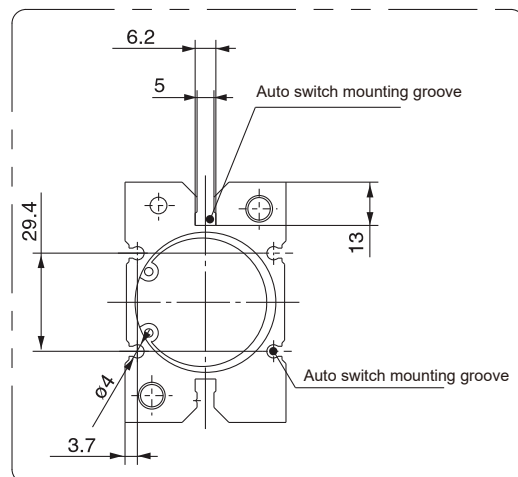

Outline drawing(mm)
Dust Cover Type
FHZJ2-16D
Double acting

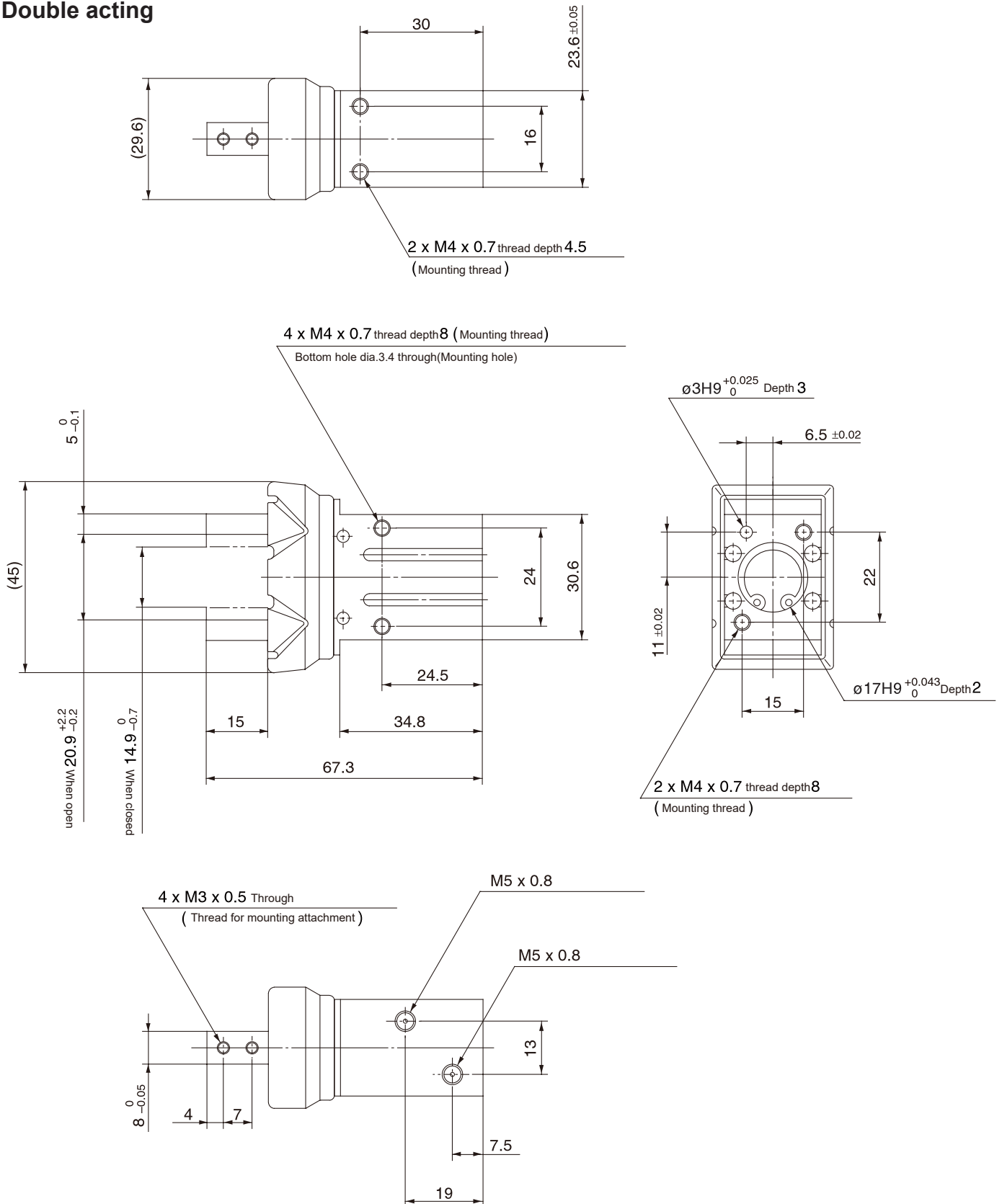

Outline drawing(mm)
FHZZL2-10
Double acting/Single acting

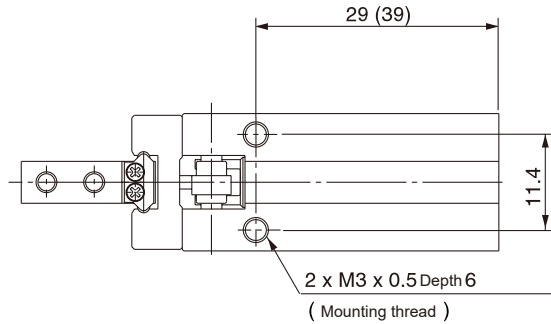

The values inside () are dimensions for single acting type.

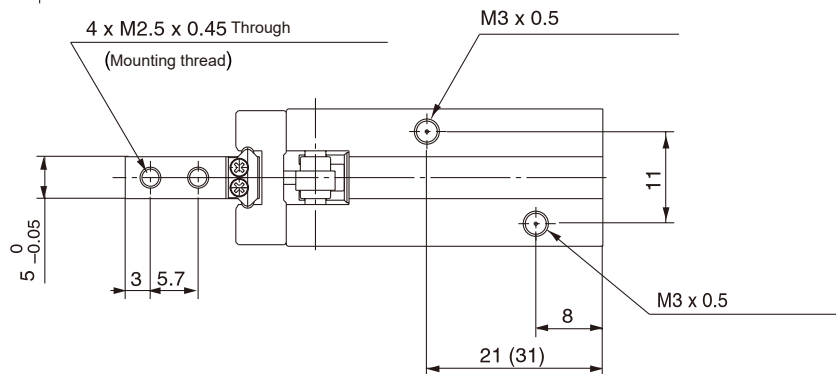
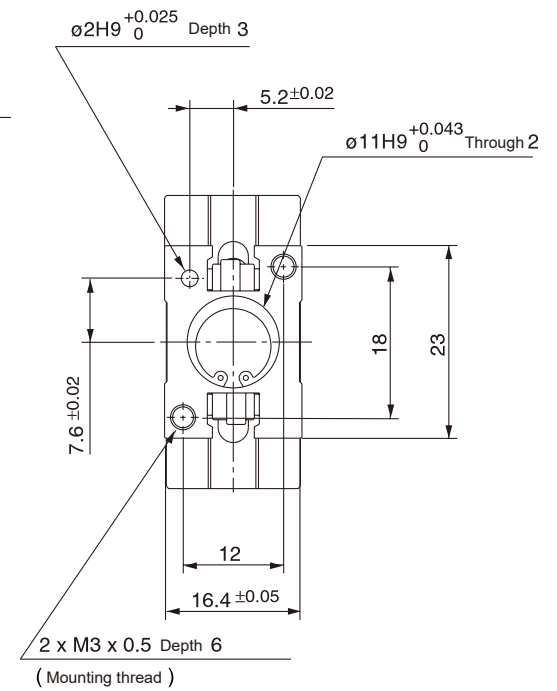
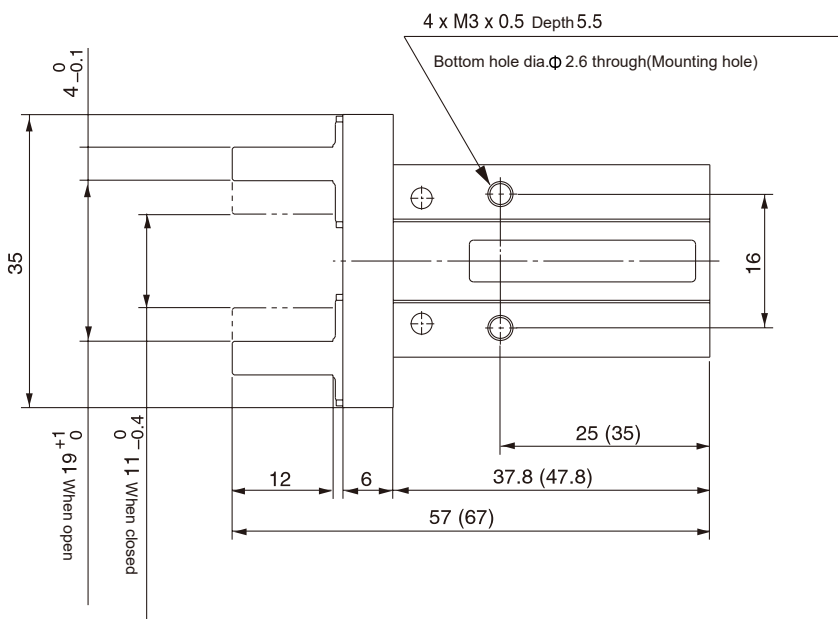

Outline drawing(mm)

FHZL2-16

Double acting/Single acting

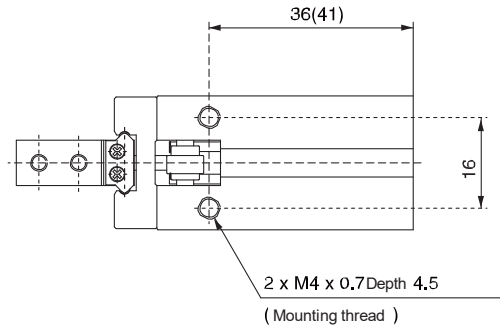

The values inside () are dimensions for single acting type.

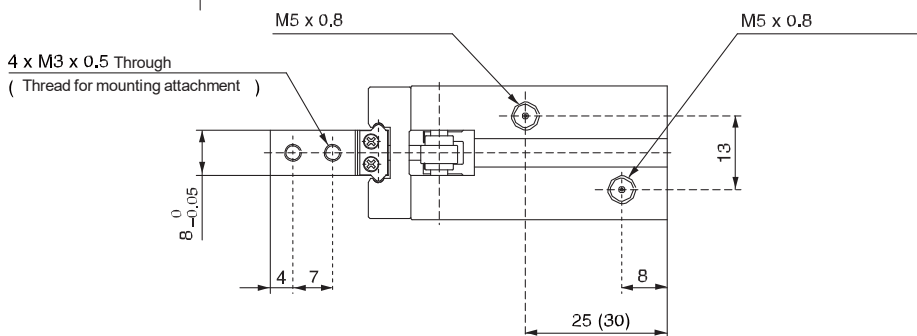
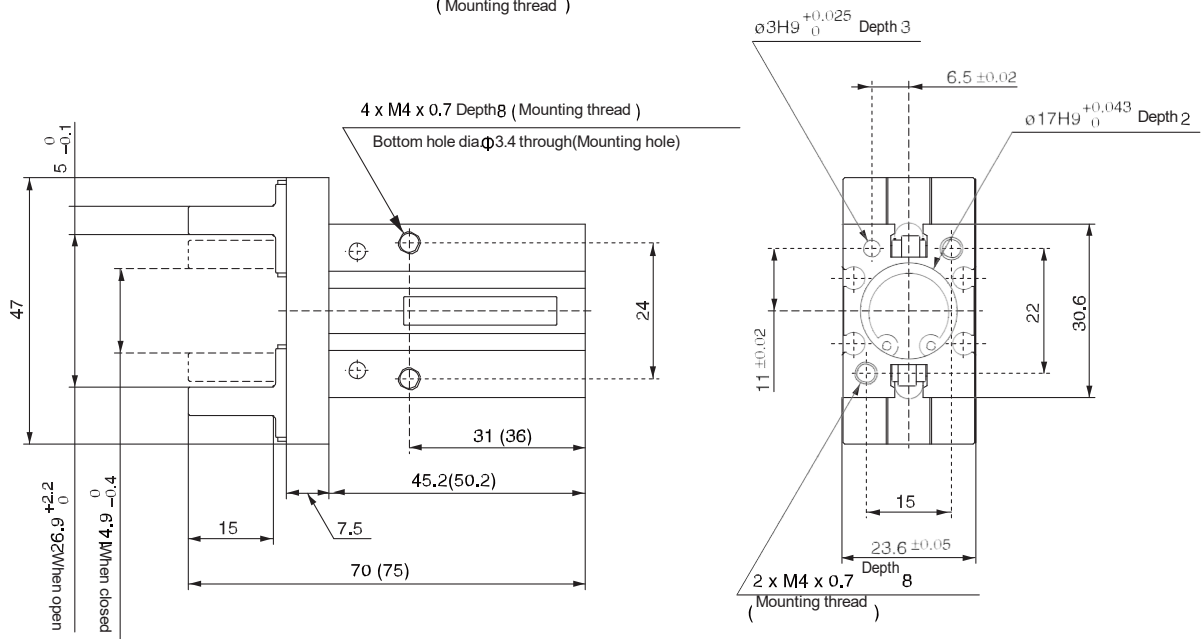

Outline drawing(mm)

FHZL2-20

Double acting/Single acting

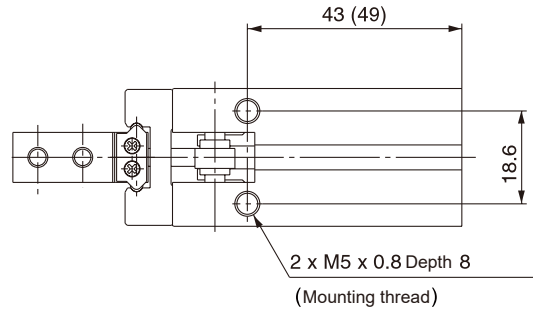

The values inside () are dimensions for single acting type.

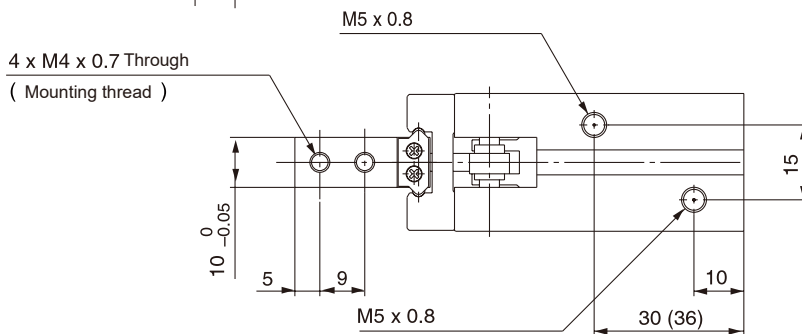
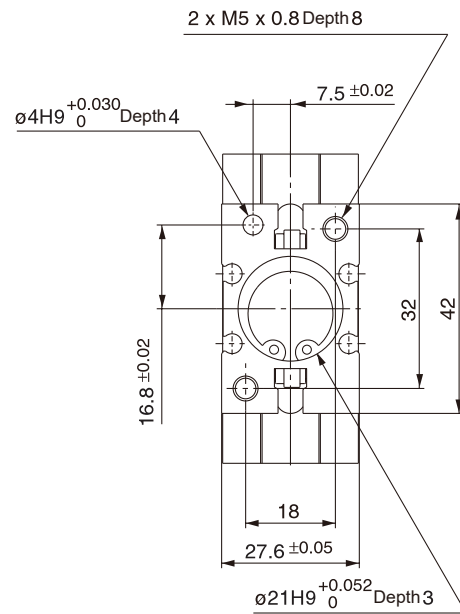
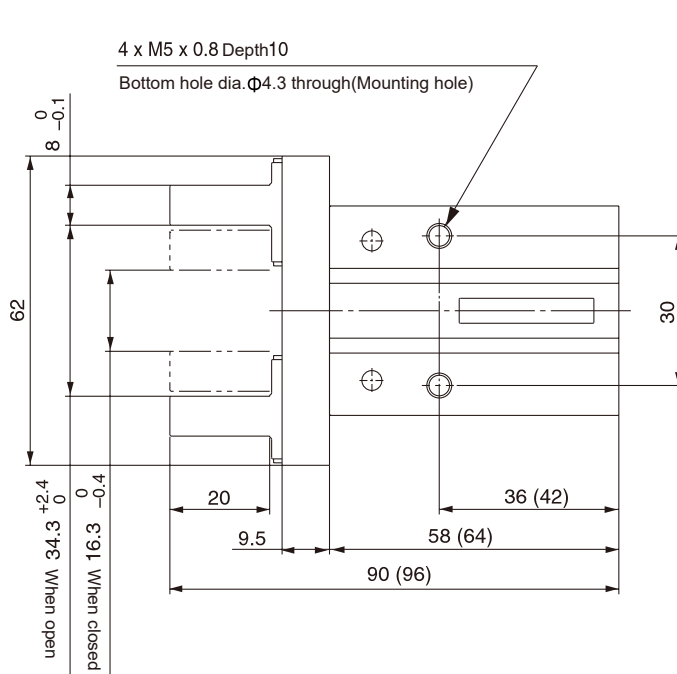

Outline drawing(mm)

FHZL2-25

Double acting/Single acting

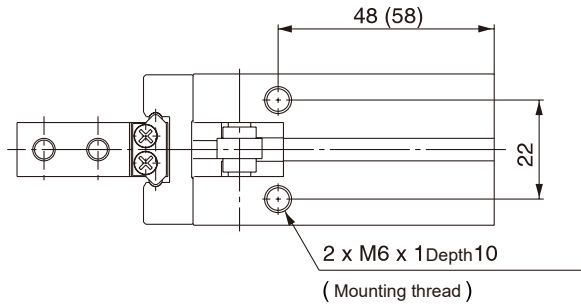

The values inside () are dimensions for single acting type.

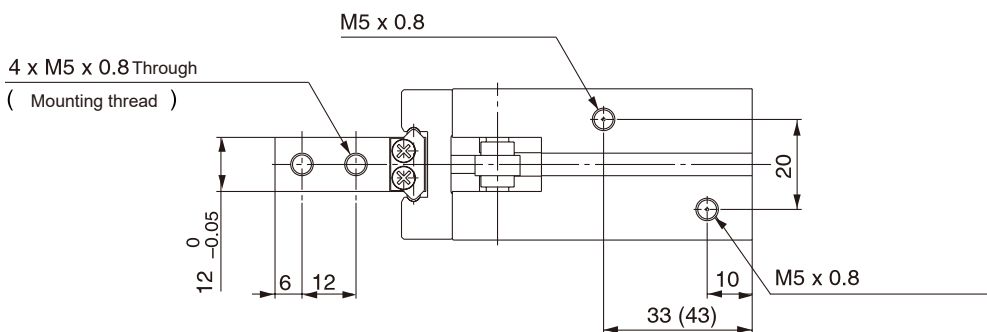
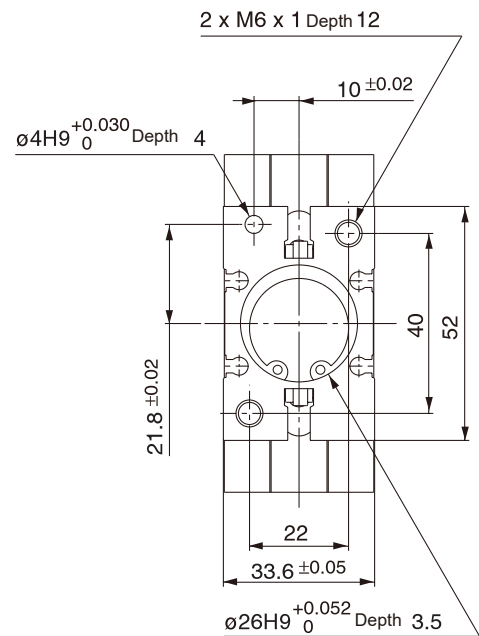
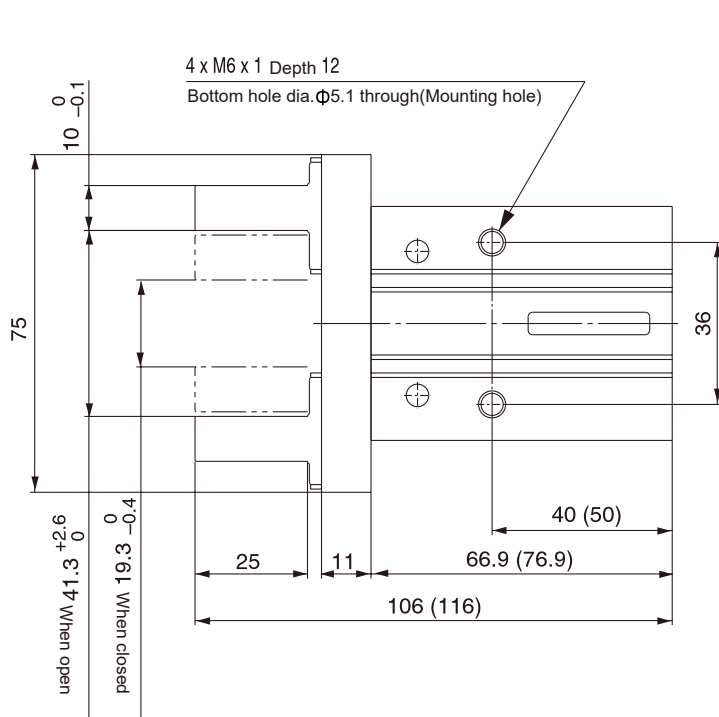

Outline drawing(mm)
Double acting
Long stroke Axial ported

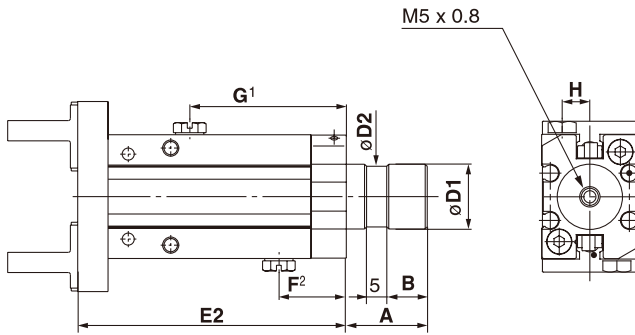

Note 1 is single acting and open type.
Note 2 is single acting and closed type.

(mm)

Model	A	B	D1	D2	E2
FHZL2-10 $\frac{S}{C} \square M$	15	7	12f8 $\begin{smallmatrix} -0.016 \\ -0.043 \end{smallmatrix}$	11	62.8
FHZL2-16 $\frac{S}{C} \square M$	20	10	16f8 $\begin{smallmatrix} -0.016 \\ -0.043 \end{smallmatrix}$	15	66.4
FHZL2-20 $\frac{S}{C} \square M$	22	12	20f8 $\begin{smallmatrix} -0.020 \\ -0.053 \end{smallmatrix}$	19	81.7
FHZL2-25 $\frac{S}{C} \square M$	25	15	25f8 $\begin{smallmatrix} -0.020 \\ -0.053 \end{smallmatrix}$	24	96.2

Other dimensions and spec. correspond to the standard type.

	F	G	H
ø10	17	40	5.5
ø16	16.7	38.7	6.5
ø20	18.2	44.2	7.5
ø25	18.3	51.3	10