

特點 Features

- 免給油：
採用含油合金，特殊軸承襯套，使活塞桿無需給油。
- 高品質；耐久佳：
氣壓缸採用高級不銹鋼材質，耐磨、耐腐蝕。
- 多樣化支架：
多種固定式及非固定式支架，供選擇。
- Special housing and bushing enables self lubrication of piston rod.
- High quality long service life.
- Cylinder mountings, available with a comprehensive range of accessories for rigid or flexible mounting.

規格 Specification

| 型號 Model | | FMJ | | |
|---|------------------------|--------------------------------|------|---------|
| 氣缸內徑 Tube I.D. (mm) | | 6 | 10 | 16 |
| 配管口徑尺寸 Port size | | M5 x 0.8 | | |
| 使用流體 Medium | | 空氣 Air | | |
| 最大使用壓力 Max operation pressure | | 7 kgf/cm ² | | |
| 最小使用壓力 Min operation pressure (kgf/cm ²) | 單動 Single acting | 引入型 Normally extended | 2.5 | 1.5 |
| | | 押出型 Normally returned | 2.0 | 1.5 |
| | 複動 Double acting | | 1.2 | 0.6 |
| 耐壓力 Proof pressure | | 10 kgf/cm ² | | |
| 周圍溫度 Ambient temperature | | -5°C ~ +60°C (不凍結 No freezing) | | |
| 給油 Lubrication | | 不需給油 Not required | | |
| 感應開關 Sensor switch | | RCS | | RCM,RCS |
| 感應開關束帶 Sensor switch band | | - | - | BM16 |
| | | BJ6 | BJ10 | BJ16 |

標準行程表 Table for standard stroke

| 作動方式 Acting type | 氣缸內徑 Tube I.D. | 行程 Stroke (mm) |
|-------------------------|-------------------|------------------------------------|
| 單動型 Single acting | Φ6 | 15,30,45,60 |
| | Φ10 | 15,30,45,60 |
| | Φ16 | 15,30,45,60,75,100,125,150 |
| 複動型 Double acting | Φ6 | 15,30,45,60 |
| | Φ10 | 15,30,45,60,75,100,125,150 |
| | Φ16 | 15,30,45,60,75,100,125,150,175,200 |

RCM 適用束帶 BM16。 Sensor switch band BM** only for RCM.

氣缸訂購代碼 Ordering Code

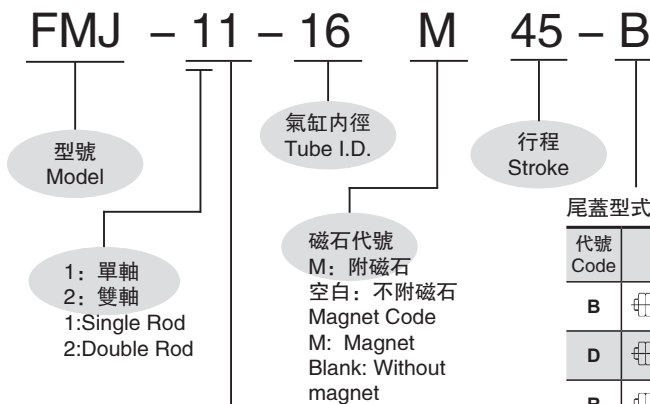

安裝配件 Mounting accessories

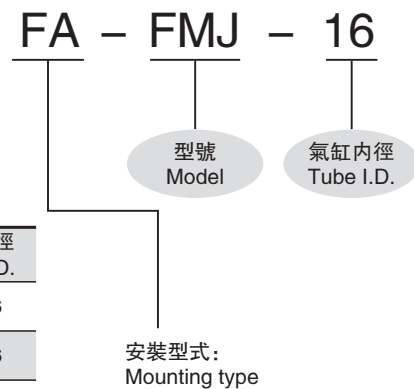

作動方式 / 桿端牙型 Style:

| 代號 Code | 記號 Symbol | 說明 Description |
|------------|--------------|---|
| 1 1 | | 複動外牙 Double acting / Male thread |
| 1 3 | | 引入單動外牙 Single acting / Normally extended male thread |
| 1 5 | | 押出單動外牙 Single acting / Normally returned male thread |
| 2 1 | | 雙軸複動外牙 Double rod / Male thread |
| 2 7 | | 雙軸可調行程外牙 Double rod / Adjustable male thread |

複動型 / 外觀尺寸 Dimensions / Double acting $\Phi 10 \sim \Phi 16$

B

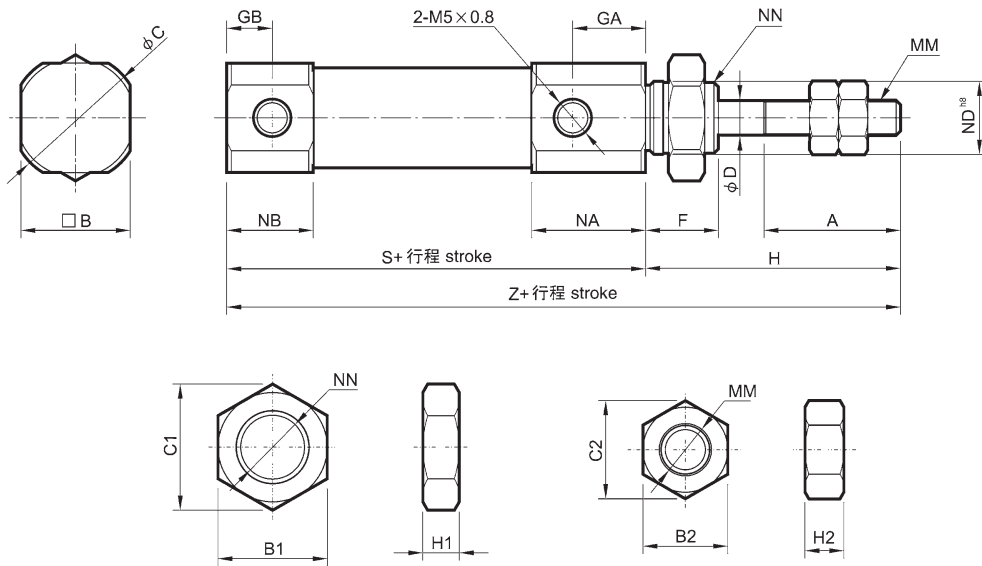

| 代號 Code 內徑 Tube I.D. | A | B | B1 | B2 | C | C1 | C2 | D | F | GA | GB | H | H1 | H2 | MM | NA | NB | ND ^{h8} | NN | S | Z |
|-------------------------|----|----|----|----|----|------|-----|---|---|----|----|----|----|-----|--------|------|-----|-----------------------------------|---------|----|----|
| 10 | 15 | 12 | 11 | 7 | 14 | 11.5 | 8.1 | 4 | 8 | 8 | 5 | 28 | 4 | 3.2 | M4×0.7 | 12.5 | 9.5 | 8 ⁰ _{-0.022} | M8×1.0 | 46 | 74 |
| 16 | 15 | 18 | 14 | 8 | 20 | 16.2 | 9.2 | 5 | 8 | 8 | 5 | 28 | 4 | 4 | M5×0.8 | 12.5 | 9.5 | 10 ⁰ _{-0.022} | M10×1.0 | 47 | 75 |

D

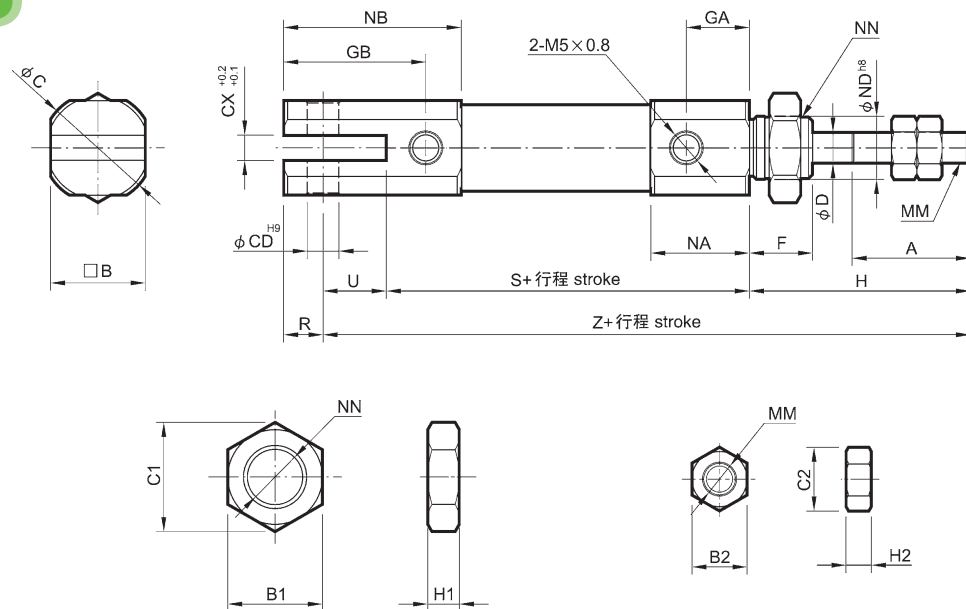

| 代號 Code 內徑 Tube I.D. | A | B | B1 | B2 | C | CD | CX | C1 | C2 | D | F | GA | GB | H | H1 | H2 | MM | NA | NB | ND ^{h8} | NN | R | S | U | Z |
|-------------------------|----|----|----|----|----|-----|-----|------|-----|---|---|----|----|----|----|-----|--------|------|------|-----------------------------------|---------|---|----|----|----|
| 10 | 15 | 12 | 11 | 7 | 14 | 3.3 | 3.2 | 12.7 | 8.1 | 4 | 8 | 8 | 18 | 28 | 4 | 3.2 | M4×0.7 | 12.5 | 22.5 | 8 ⁰ _{-0.022} | M8×1.0 | 5 | 46 | 8 | 82 |
| 16 | 15 | 18 | 14 | 8 | 20 | 5 | 6.5 | 16.2 | 9.2 | 5 | 8 | 8 | 23 | 28 | 4 | 4 | M5×0.8 | 12.5 | 27.5 | 10 ⁰ _{-0.022} | M10×1.0 | 8 | 47 | 10 | 85 |

複動型 / 外觀尺寸 Dimensions / Double acting $\Phi 6 \sim \Phi 16$

R

FMJ-6

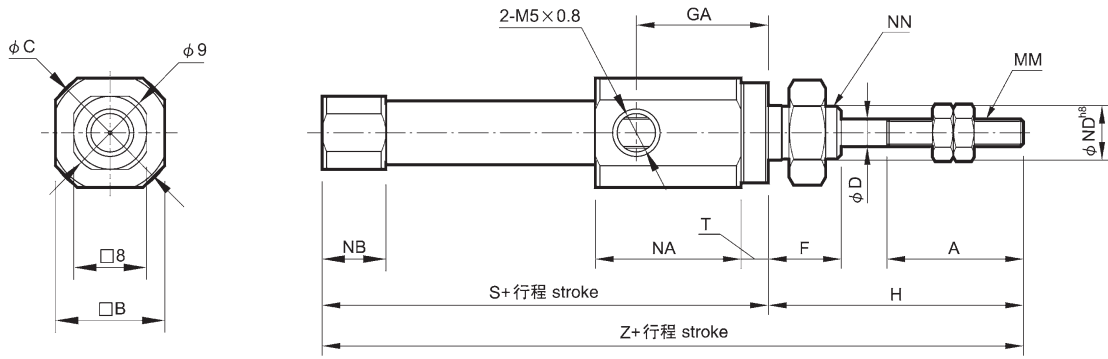

FMJ-10 / FMJ-16

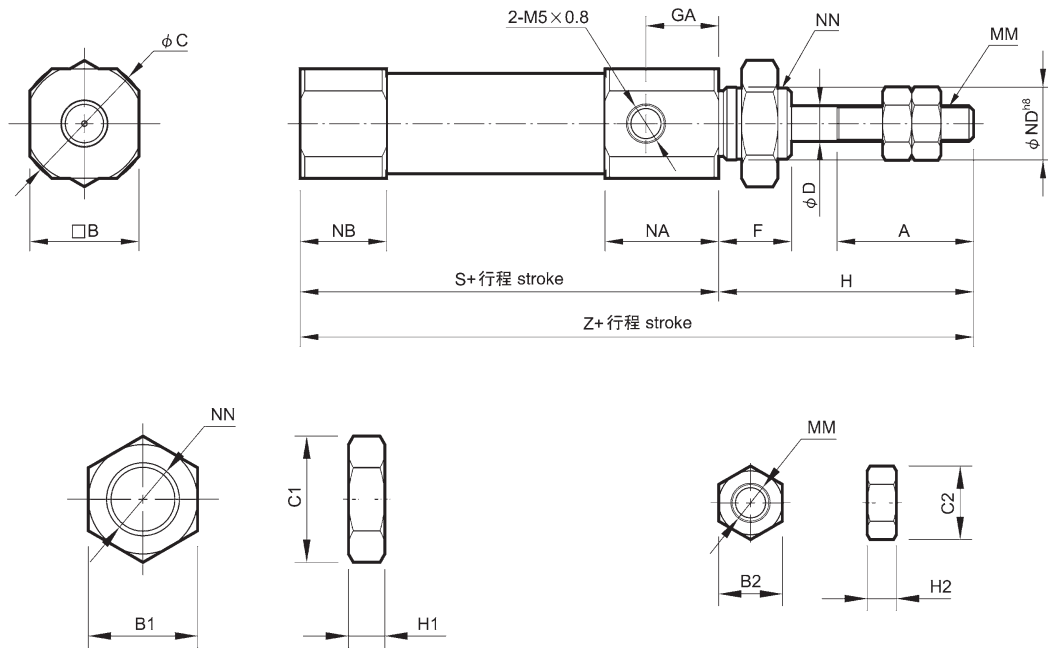

| 代號 Code 內徑 Tube I.D. | A | B | B1 | B2 | C | C1 | C2 | D | F | GA | H | H1 | H2 | MM | NA | NB | ND ^{h8} | NN | S | T | Z |
|-------------------------|----|----|----|-----|----|------|-----|---|---|------|----|----|-----|--------|------|-----|-----------------------------------|---------|----|---|----|
| 6 | 15 | 12 | 8 | 5.5 | 14 | 9.2 | 6.4 | 3 | 8 | 14.5 | 28 | 4 | 2.4 | M3×0.5 | 16 | 7 | 6 ⁰ _{-0.022} | M6×1.0 | 49 | 3 | 77 |
| 10 | 15 | 12 | 11 | 7 | 14 | 12.7 | 8.1 | 4 | 8 | 8 | 28 | 4 | 3.2 | M4×0.7 | 12.5 | 9.5 | 8 ⁰ _{-0.022} | M8×1.0 | 46 | | 74 |
| 16 | 15 | 18 | 14 | 8 | 20 | 16.2 | 9.2 | 5 | 8 | 8 | 28 | 4 | 4 | M5×0.8 | 12.5 | 9.5 | 10 ⁰ _{-0.022} | M10×1.0 | 47 | | 75 |

感應開關 Sensor switch: RCM
感應開關束帶 Sensor switch band: BM**

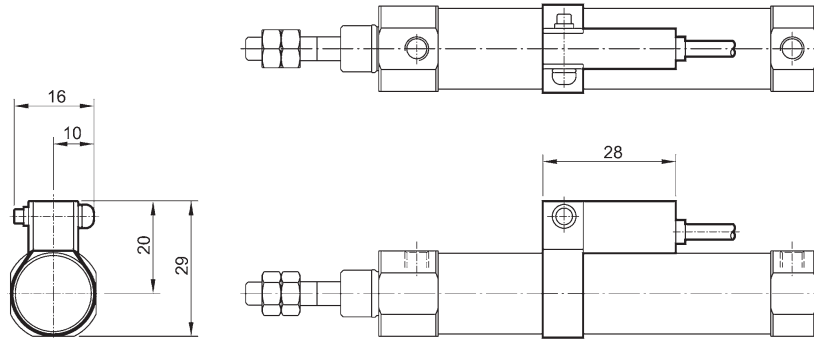

感應開關 Sensor switch: RCS
感應開關束帶 Sensor switch band: BJ**

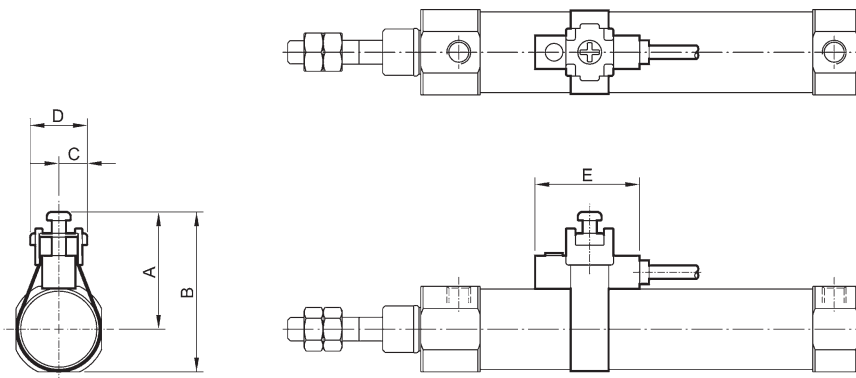

| 代號 Code 內徑 Tube I.D. | A | B | C | D | E |
|-------------------------|------|------|---|----|----|
| 6 | 18.1 | 24.1 | 6 | 12 | 22 |
| 10 | 20.1 | 26.1 | 6 | 12 | 22 |
| 16 | 23.4 | 32.4 | 6 | 12 | 22 |

複動型 / 安裝配件 Mounting accessories / Double acting $\Phi 6 \sim \Phi 16$

LB

$\Phi 6$

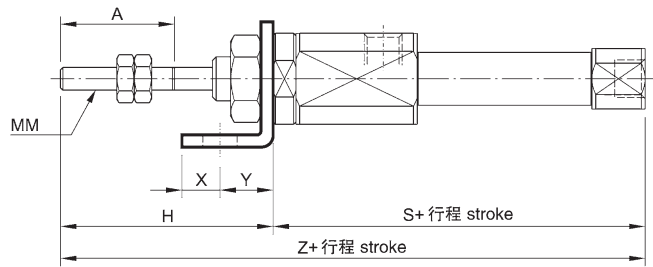
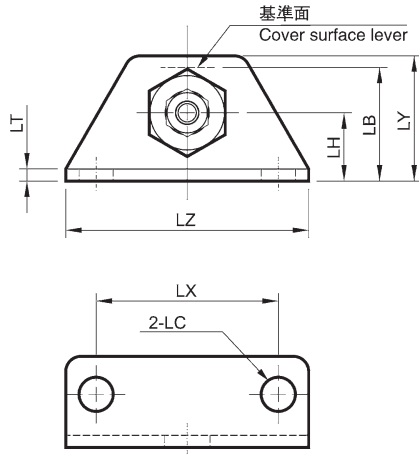

$\Phi 10, \Phi 16$

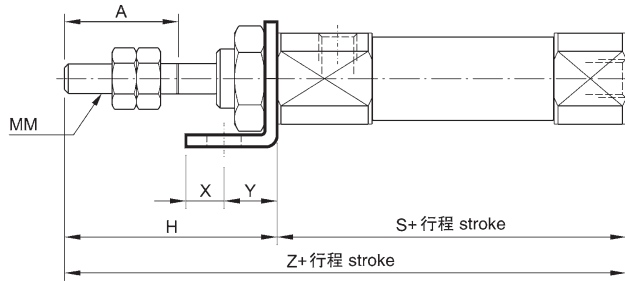
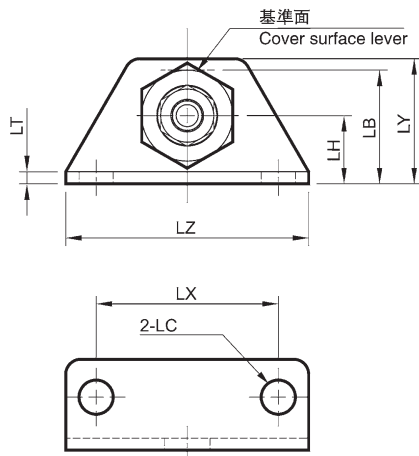

| 代號 Code 內徑 Tube I.D. | A | H | LB | LC | LH | LT | LX | LY | LZ | MM | S | X | Y | Z |
|-------------------------|----|----|----|-----|----|-----|----|------|----|----------|----|---|---|----|
| 6 | 15 | 28 | 15 | 4.5 | 9 | 1.6 | 24 | 16.5 | 32 | M3 × 0.5 | 49 | 5 | 7 | 77 |
| 10 | 15 | 28 | 15 | 4.5 | 9 | 1.6 | 24 | 16.5 | 32 | M4 × 0.7 | 46 | 5 | 7 | 74 |
| 16 | 15 | 28 | 23 | 5.5 | 14 | 2.3 | 33 | 25 | 42 | M5 × 0.8 | 47 | 6 | 9 | 75 |

複動型 / 安裝配件 Mounting accessories / Double acting $\Phi 6 \sim \Phi 16$

FA

$\Phi 6$

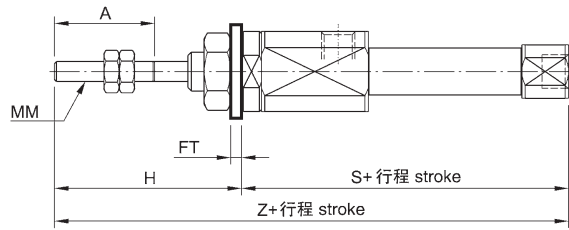
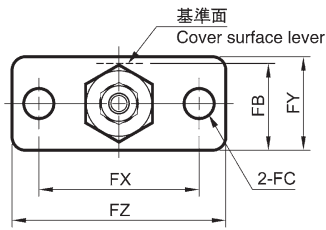

$\Phi 10 \sim \Phi 16$

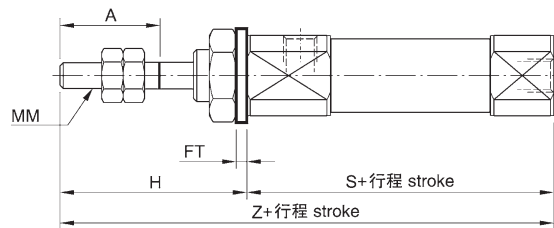
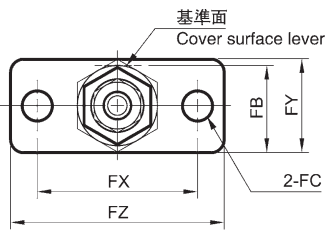

| 代號 Code 內徑 Tube I.D. | A | FB | FC | FT | FX | FY | FZ | H | MM | S | Z |
|-------------------------|----|----|-----|-----|----|----|----|----|----------|----|----|
| 6 | 15 | 13 | 4.5 | 1.6 | 24 | 14 | 32 | 28 | M3 × 0.5 | 49 | 77 |
| 10 | 15 | 13 | 4.5 | 1.6 | 24 | 14 | 32 | 28 | M4 × 0.7 | 46 | 74 |
| 16 | 15 | 19 | 5.5 | 2.3 | 33 | 20 | 42 | 28 | M5 × 0.8 | 47 | 75 |

T

(另購 I 接頭 + 插銷)
I+Pin (Extra purchase)

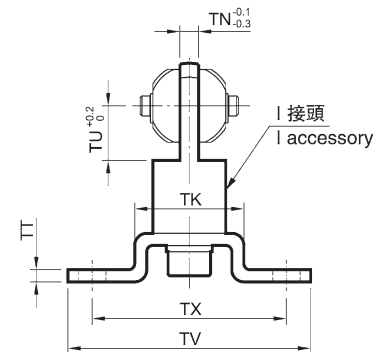
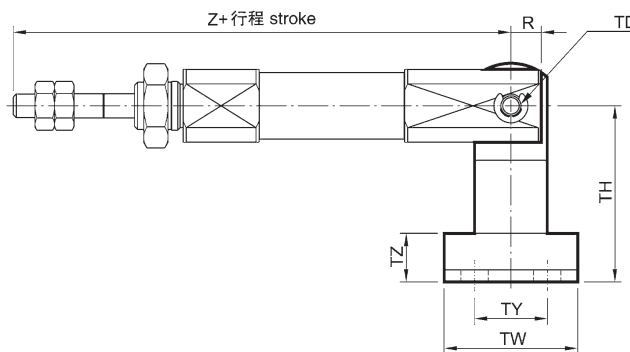
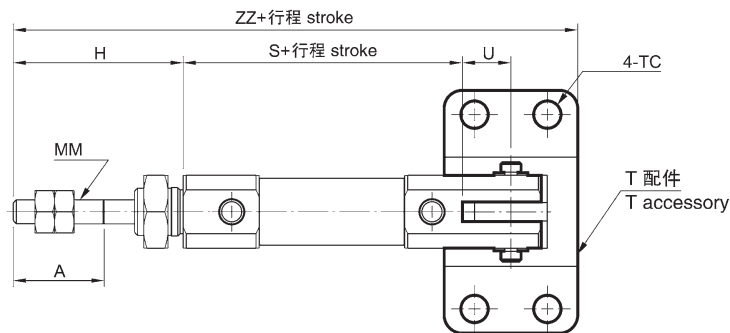

| 代號 Code 內徑 Tube I.D. | A | H | MM | R | S | TC | TD ^{H10} | TH | TK | TN | TT | TU | TV | TW | TX | TY | TZ | U | Z | ZZ |
|-------------------------|----|----|----------|---|----|-----|--------------------------------------|----|----|-----|-----|----|----|----|----|----|----|----|----|----|
| 10 | 15 | 28 | M4 × 0.7 | 5 | 46 | 4.5 | 3.3 ^{+0.048} / ₀ | 29 | 18 | 3.1 | 2 | 9 | 40 | 22 | 32 | 12 | 8 | 8 | 8 | 93 |
| 16 | 15 | 28 | M5 × 0.8 | 8 | 47 | 4.5 | 5 ^{+0.048} / ₀ | 35 | 20 | 6.4 | 2.3 | 14 | 48 | 28 | 38 | 16 | 10 | 10 | 10 | 99 |

筆型氣壓缸
Pen Cylinders

FMJ

單動引入型 / 外觀尺寸 Dimensions / Normally extended $\Phi 6 \sim \Phi 16$

13

$\Phi 6$

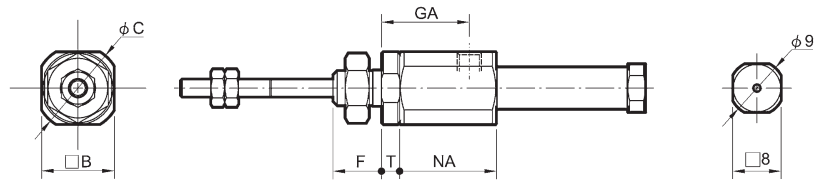

$\Phi 10, \Phi 16$

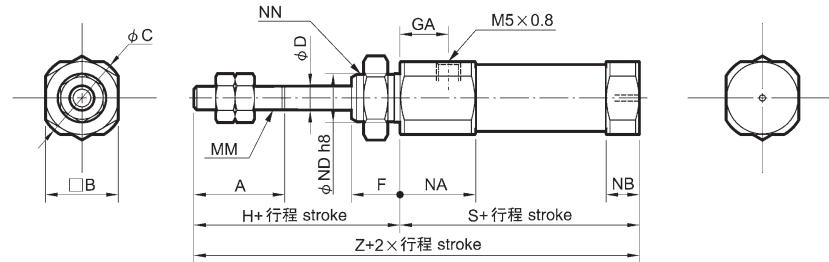

| 代號 Code 內徑 Tube I.D. | A | B | C | D | F | GA | H | MM | NA | NB | ND | NN | T |
|-------------------------|----|----|----|---|---|------|----|----------|------|-----|-----------------------------------|-----------|---|
| 6 | 15 | 12 | 14 | 3 | 8 | 14.5 | 28 | M3 × 0.5 | 16 | 3 | 6 ⁰ _{-0.018} | M6 × 1.0 | 3 |
| 10 | 15 | 12 | 14 | 4 | 8 | 8 | 28 | M4 × 0.7 | 12.5 | 5.5 | 8 ⁰ _{-0.022} | M8 × 1.0 | - |
| 16 | 15 | 18 | 20 | 5 | 8 | 8 | 28 | M5 × 0.8 | 12.5 | 5.5 | 10 ⁰ _{-0.022} | M10 × 1.0 | - |

| 代號 Code 行程 Stroke 內徑 I.D. | ※S | | | | | | | | ※Z | | | | | | | |
|---------------------------------|----------------|----------------|----------------|----------------|-------|--------|---------|---------|----------------|----------------|----------------|------------------|-------|--------|---------|---------|
| | 5~15 | 16~30 | 31~45 | 46~60 | 61~75 | 76~100 | 101~125 | 126~150 | 5~15 | 16~30 | 31~45 | 46~60 | 61~75 | 76~100 | 101~125 | 126~150 |
| 6 | 46.5 (51.5) | 55.5 (60.5) | 59.5 (64.5) | 73.5 (78.5) | - | - | - | - | 74.5 (79.5) | 83.5 (88.5) | 87.5 (92.5) | 101.5 (106.5) | - | - | - | - |
| 10 | 48.5 | 56 | 68 | 80 | - | - | - | - | 76.5 | 84 | 96 | 108 | - | - | - | - |
| 16 | 48.5 | 57 | 69 | 81 | 87 | 111 | 129 | 141 | 76.5 | 85 | 97 | 109 | 115 | 139 | 157 | 169 |

※ (S) (Z) 括弧內屬具有磁性環之寸。 ※ (S), (Z) () indicate the size of that with magnet ring.

安裝配件 Mounting accessories

LB

$\Phi 6$

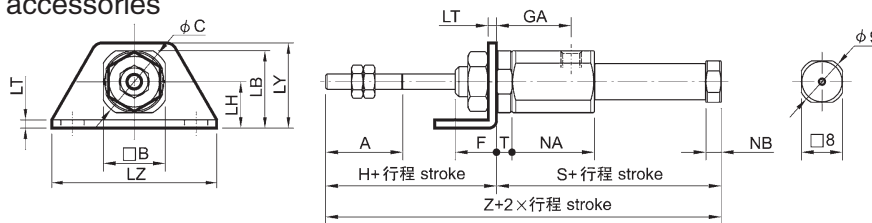

$\Phi 10, \Phi 16$

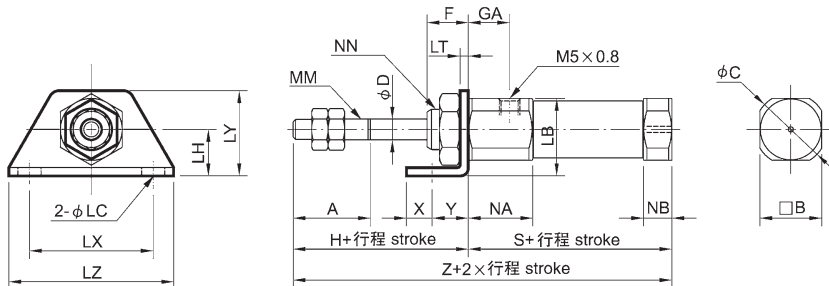

| 代號 Code 內徑 Tube I.D. | A | B | C | D | F | GA | H | LB | LC | LH | LT | LX | LY | LZ | MM | NA | NB | NN | T | X | Y |
|-------------------------|----|----|----|---|---|------|----|----|-----|----|-----|----|------|----|----------|------|-----|-----------|---|---|---|
| 6 | 15 | 12 | 14 | 3 | 8 | 14.5 | 28 | 15 | 4.5 | 9 | 1.6 | 24 | 16.5 | 32 | M3 × 0.5 | 16 | 3 | M6 × 1.0 | 3 | 5 | 7 |
| 10 | 15 | 12 | 14 | 4 | 8 | 8 | 28 | 15 | 4.5 | 9 | 1.6 | 24 | 16.5 | 32 | M4 × 0.7 | 12.5 | 5.5 | M8 × 1.0 | - | 5 | 7 |
| 16 | 15 | 18 | 20 | 5 | 8 | 8 | 28 | 23 | 5.5 | 14 | 2.3 | 33 | 25 | 42 | M5 × 0.8 | 12.5 | 5.5 | M10 × 1.0 | - | 6 | 9 |

| 代號 Code 行程 Stroke 內徑 I.D. | ※S | | | | | | | | ※Z | | | | | | | |
|---------------------------------|----------------|----------------|----------------|----------------|-------|--------|---------|---------|----------------|----------------|----------------|------------------|-------|--------|---------|---------|
| | 5~15 | 16~30 | 31~45 | 46~60 | 61~75 | 76~100 | 101~125 | 126~150 | 5~15 | 16~30 | 31~45 | 46~60 | 61~75 | 76~100 | 101~125 | 126~150 |
| 6 | 46.5 (51.5) | 55.5 (60.5) | 59.5 (64.5) | 73.5 (78.5) | - | - | - | - | 74.5 (79.5) | 83.5 (88.5) | 87.5 (92.5) | 101.5 (106.5) | - | - | - | - |
| 10 | 48.5 | 56 | 68 | 80 | - | - | - | - | 76.5 | 84 | 96 | 108 | - | - | - | - |
| 16 | 48.5 | 57 | 69 | 81 | 87 | 111 | 129 | 141 | 76.5 | 85 | 97 | 109 | 115 | 139 | 157 | 169 |

※ (S) (Z) 括弧內屬具有磁性環之寸。 ※ (S), (Z) () indicate the size of that with magnet ring.

單動引入型 / 安裝配件 Mounting accessories / Normally extended $\Phi 6 \sim \Phi 16$

FA

$\Phi 6$

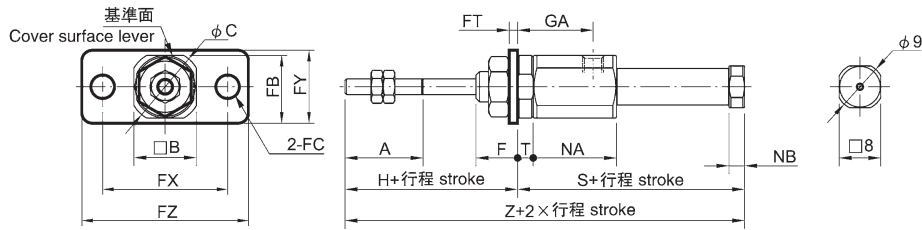

$\Phi 10, \Phi 16$

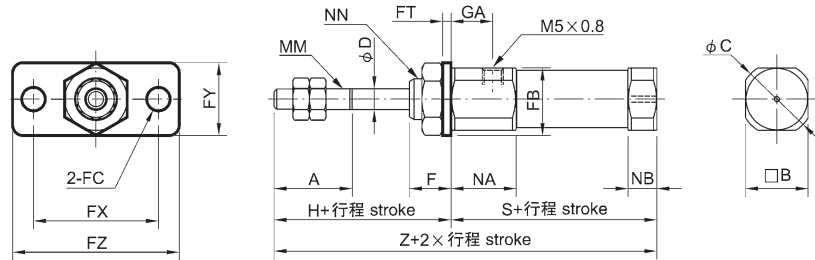

| 代號 Code 內徑 Tube I.D. | A | B | C | D | F | FB | FC | FT | FX | FY | FZ | GA | H | MM | NA | NB | NN | T | X | Y |
|-------------------------|----|----|----|---|---|----|-----|-----|----|----|----|------|----|--------|------|-----|---------|---|---|---|
| 6 | 15 | 12 | 14 | 3 | 8 | 11 | 4.5 | 1.6 | 24 | 14 | 32 | 14.5 | 28 | M3×0.5 | 16 | 3 | M6×1.0 | 3 | 5 | 7 |
| 10 | 15 | 12 | 14 | 4 | 8 | 13 | 4.5 | 1.6 | 24 | 14 | 32 | 8 | 28 | M4×0.7 | 12.5 | 5.5 | M8×1.0 | - | 5 | 7 |
| 16 | 15 | 18 | 20 | 5 | 8 | 19 | 5.5 | 2.3 | 33 | 20 | 42 | 8 | 28 | M5×0.8 | 12.5 | 5.5 | M10×1.0 | - | 6 | 9 |

| 代號 Code 行程 Stroke 內徑 I.D. | ※S | | | | | | | | ※Z | | | | | | | |
|---------------------------------|----------------|----------------|----------------|----------------|-------|--------|---------|---------|----------------|----------------|----------------|------------------|-------|--------|---------|---------|
| | 5-15 | 16-30 | 31-45 | 46-60 | 61-75 | 76-100 | 101-125 | 126-150 | 5-15 | 16-30 | 31-45 | 46-60 | 61-75 | 76-100 | 101-125 | 126-150 |
| 6 | 46.5 (51.5) | 55.5 (60.5) | 59.5 (64.5) | 73.5 (78.5) | - | - | - | - | 74.5 (79.5) | 83.5 (88.5) | 87.5 (92.5) | 101.5 (106.5) | - | - | - | - |
| 10 | 48.5 | 56 | 68 | 80 | - | - | - | - | 76.5 | 84 | 96 | 108 | - | - | - | - |
| 16 | 48.5 | 57 | 69 | 81 | 87 | 111 | 129 | 141 | 76.5 | 85 | 97 | 109 | 115 | 139 | 157 | 169 |

※ (S) (Z) 括弧內屬具有磁性環之尺寸。 ※ (S), (Z) () indicate the size of that with magnet ring.

T

(另購 I 接頭 + 插銷)
I+Pin (Extra purchase)

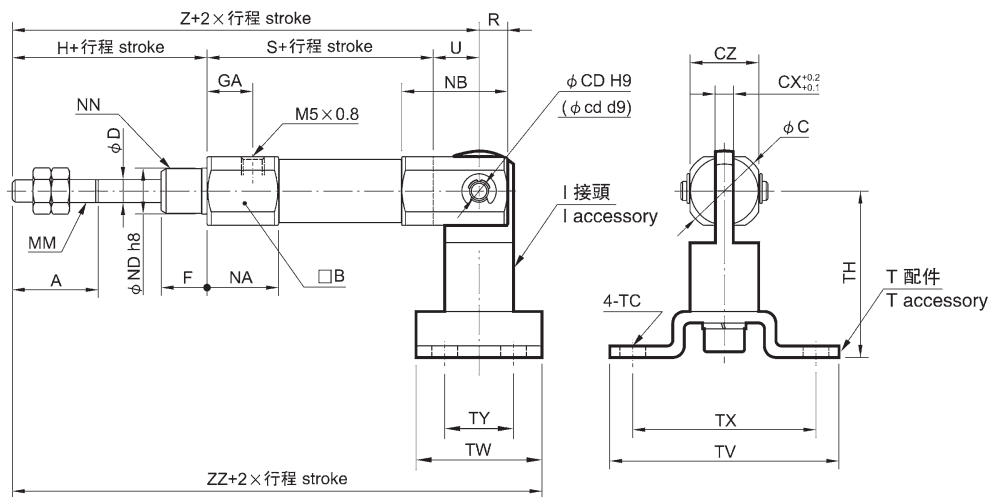

| 代號 Code 內徑 Tube I.D. | A | B | C | CD (cd) | CX | CZ | D | F | GA | H | MM | NA | NB | ND | NN | R | TC | TH | TV | TW | TX | TY | U |
|-------------------------|----|----|----|------------|-----|----|---|---|----|----|--------|------|------|-----------------------------------|---------|---|-----|----|----|----|----|----|----|
| 10 | 15 | 12 | 14 | 3.3 | 3.2 | 12 | 4 | 8 | 8 | 28 | M4×0.7 | 12.5 | 18.5 | 8 ⁰ _{-0.022} | M8×1.0 | 5 | 4.5 | 29 | 40 | 22 | 32 | 12 | 8 |
| 16 | 15 | 18 | 20 | 5 | 6.5 | 18 | 5 | 8 | 8 | 28 | M5×0.8 | 12.5 | 23.5 | 10 ⁰ _{-0.022} | M10×1.0 | 8 | 5.5 | 35 | 48 | 28 | 38 | 16 | 10 |

| 代號 Code 行程 Stroke 內徑 I.D. | S | | | | | | | | Z | | | | | | | | ZZ | | | | | | | |
|---------------------------------|------|-------|-------|-------|-------|--------|---------|---------|------|-------|-------|-------|-------|--------|---------|---------|-------|-------|-------|-------|-------|--------|---------|---------|
| | 5-15 | 16-30 | 31-45 | 46-60 | 61-75 | 76-100 | 101-125 | 126-150 | 5-15 | 16-30 | 31-45 | 46-60 | 61-75 | 76-100 | 101-125 | 126-150 | 5-15 | 16-30 | 31-45 | 46-60 | 61-75 | 76-100 | 101-125 | 126-150 |
| 10 | 48.5 | 56 | 68 | 80 | - | - | - | - | 84.5 | 92 | 104 | 116 | - | - | - | - | 95.5 | 103 | 115 | 127 | - | - | - | - |
| 16 | 48.5 | 57 | 69 | 81 | 87 | 111 | 129 | 141 | 86.5 | 95 | 107 | 119 | 125 | 149 | 167 | 179 | 100.5 | 109 | 121 | 133 | 139 | 163 | 181 | 193 |

筆型氣壓缸
Pen Cylinders

FMJ

單動伸出型 / 外觀尺寸 Dimensions / Normally returned $\Phi 6 \sim \Phi 16$

15

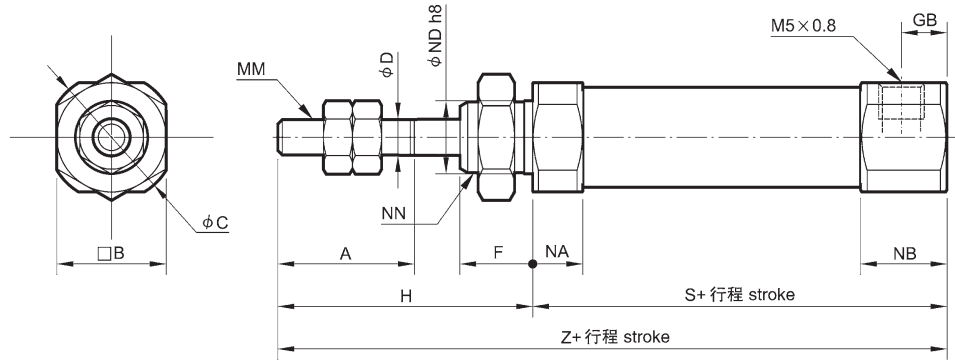

| 代號 Code 內徑 Tube I.D. | A | B | C | D | F | GB | H | MM | NA | NB | ND | NN |
|-------------------------|----|----|----|---|---|----|----|--------|-----|-----|-----------------------------------|---------|
| 6 | 15 | 8 | 9 | 3 | 8 | - | 28 | M3×0.5 | 3 | 7 | 6 ⁰ _{-0.018} | M6×1.0 |
| 10 | 15 | 12 | 14 | 4 | 8 | 5 | 28 | M4×0.7 | 5.5 | 9.5 | 8 ⁰ _{-0.022} | M8×1.0 |
| 16 | 15 | 18 | 20 | 5 | 8 | 5 | 28 | M5×0.8 | 5.5 | 9.5 | 10 ⁰ _{-0.022} | M10×1.0 |

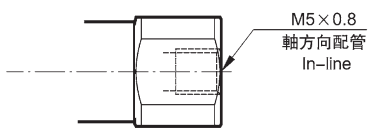

| 代號 Code 行程 Stroke 內徑 I.D. | ※S | | | | | | | | ※Z | | | | | | | |
|---------------------------------|----------------|----------------|----------------|----------------|-------|--------|---------|---------|----------------|----------------|----------------|----------------|-------|--------|---------|---------|
| | 5~15 | 16~30 | 31~45 | 46~60 | 61~75 | 76~100 | 101~125 | 126~150 | 5~15 | 16~30 | 31~45 | 46~60 | 61~75 | 76~100 | 101~125 | 126~150 |
| 6 | 34.5 (39.5) | 43.5 (48.5) | 47.5 (52.5) | 61.5 (66.5) | - | - | - | - | 62.5 (67.5) | 71.5 (76.5) | 75.5 (80.5) | 89.5 (94.5) | - | - | - | - |
| 10 | 45.5 | 53 | 65 | 77 | - | - | - | - | 73.5 | 81 | 93 | 105 | - | - | - | - |
| 16 | 45.5 | 54 | 66 | 78 | 84 | 108 | 126 | 138 | 73.5 | 82 | 94 | 106 | 112 | 136 | 154 | 166 |

※ (S) (Z) 括弧內屬具有磁性環之寸。 ※ (S), (Z) () indicate the size of that with magnet ring.

安裝配件 Mounting accessories

LB

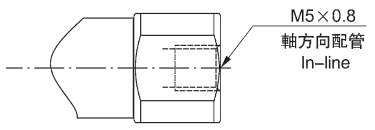
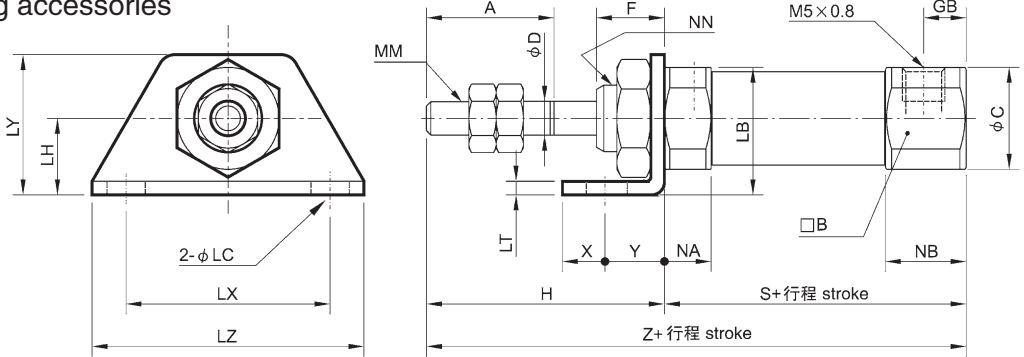

| 代號 Code 內徑 Tube I.D. | A | B | C | D | F | GB | H | LB | LC | LH | LT | LX | LY | LZ | MM | NA | NB | NN | X | Y |
|-------------------------|----|----|----|---|---|----|----|----|-----|----|-----|----|------|----|--------|-----|-----|---------|---|---|
| 6 | 15 | 8 | 9 | 3 | 8 | - | 28 | 13 | 4.5 | 9 | 1.6 | 24 | 16.5 | 32 | M3×0.5 | 3 | 7 | M6×1.0 | 5 | 7 |
| 10 | 15 | 12 | 14 | 4 | 8 | 5 | 28 | 15 | 4.5 | 9 | 1.6 | 24 | 16.5 | 32 | M4×0.7 | 5.5 | 9.5 | M8×1.0 | 5 | 7 |
| 16 | 15 | 18 | 20 | 5 | 8 | 5 | 28 | 23 | 5.5 | 14 | 2.3 | 33 | 25 | 42 | M5×0.8 | 5.5 | 9.5 | M10×1.0 | 6 | 9 |

| 代號 Code 行程 Stroke 內徑 I.D. | ※S | | | | | | | | ※Z | | | | | | | |
|---------------------------------|----------------|----------------|----------------|----------------|-------|--------|---------|---------|----------------|----------------|----------------|----------------|-------|--------|---------|---------|
| | 5~15 | 16~30 | 31~45 | 46~60 | 61~75 | 76~100 | 101~125 | 126~150 | 5~15 | 16~30 | 31~45 | 46~60 | 61~75 | 76~100 | 101~125 | 126~150 |
| 6 | 34.5 (39.5) | 43.5 (48.5) | 47.5 (52.5) | 61.5 (66.5) | - | - | - | - | 62.5 (67.5) | 71.5 (76.5) | 75.5 (80.5) | 89.5 (94.5) | - | - | - | - |
| 10 | 45.5 | 53 | 65 | 77 | - | - | - | - | 73.5 | 81 | 93 | 105 | - | - | - | - |
| 16 | 45.5 | 54 | 66 | 78 | 84 | 108 | 126 | 138 | 73.5 | 82 | 94 | 106 | 112 | 136 | 154 | 166 |

※ (S) (Z) 括弧內屬具有磁性環之寸。 ※ (S), (Z) () indicate the size of that with magnet ring.

單動伸出型 / 安裝配件 Mounting accessories / Normally returned $\Phi 6 \sim \Phi 16$

FA

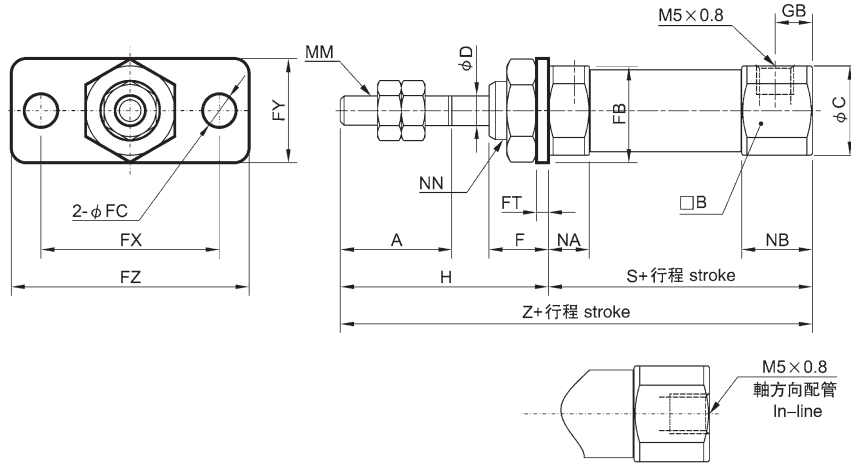

| 代號 Code 內徑 Tube I.D. | A | B | C | D | F | GB | H | FB | FC | FT | FX | FY | FZ | MM | NA | NB | NN | X | Y |
|-------------------------|----|----|----|---|---|----|----|----|-----|-----|----|----|----|--------|-----|-----|---------|---|---|
| 6 | 15 | 8 | 9 | 3 | 8 | - | 28 | 11 | 4.5 | 1.6 | 24 | 14 | 32 | M3x0.5 | 3 | 7 | M6x1.0 | 5 | 7 |
| 10 | 15 | 12 | 14 | 4 | 8 | 5 | 28 | 13 | 4.5 | 1.6 | 24 | 14 | 32 | M4x0.7 | 5.5 | 9.5 | M8x1.0 | 5 | 7 |
| 16 | 15 | 18 | 20 | 5 | 8 | 5 | 28 | 19 | 5.5 | 2.3 | 33 | 20 | 42 | M5x0.8 | 5.5 | 9.5 | M10x1.0 | 6 | 9 |

| 代號 Code 行程 Stroke 內徑 I.D. | ※S | | | | | | | | ※Z | | | | | | | |
|---------------------------------|----------------|----------------|----------------|----------------|-------|--------|---------|---------|----------------|----------------|----------------|----------------|-------|--------|---------|---------|
| | 5~15 | 16~30 | 31~45 | 46~60 | 61~75 | 76~100 | 101~125 | 126~150 | 5~15 | 16~30 | 31~45 | 46~60 | 61~75 | 76~100 | 101~125 | 126~150 |
| 6 | 34.5 (39.5) | 43.5 (48.5) | 47.5 (52.5) | 61.5 (66.5) | - | - | - | - | 62.5 (67.5) | 71.5 (76.5) | 75.5 (80.5) | 89.5 (94.5) | - | - | - | - |
| 10 | 45.5 | 53 | 65 | 77 | - | - | - | - | 73.5 | 81 | 93 | 105 | - | - | - | - |
| 16 | 45.5 | 54 | 66 | 78 | 84 | 108 | 126 | 138 | 73.5 | 82 | 94 | 106 | 112 | 136 | 154 | 166 |

T

(另購 I 接頭 + 插銷)
I+Pin (Extra purchase)

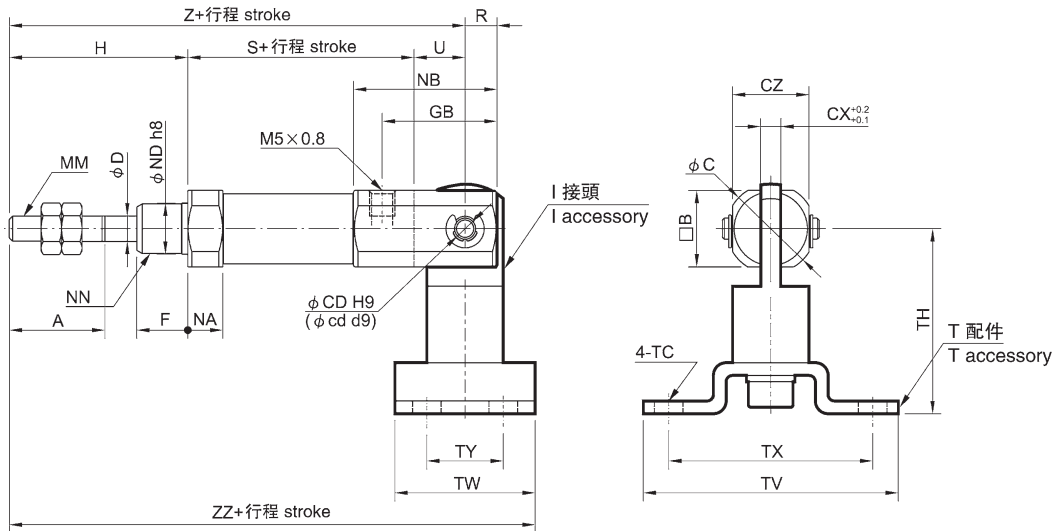

| 代號 Code 內徑 Tube I.D. | A | B | C | CD (cd) | CX | CZ | D | F | GB | H | MM | NA | NB | ND | NN | R | TC | TH | TV | TW | TX | TY | U |
|-------------------------|----|----|----|---------|-----|----|---|---|----|----|--------|-----|------|-----------------------------------|---------|---|-----|----|----|----|----|----|----|
| 10 | 15 | 12 | 14 | 3.3 | 3.2 | 12 | 4 | 8 | 18 | 28 | M4x0.7 | 5.5 | 22.5 | 8 ⁰ _{-0.022} | M8x1.0 | 5 | 4.5 | 29 | 40 | 22 | 32 | 12 | 8 |
| 16 | 15 | 18 | 20 | 5 | 6.5 | 18 | 5 | 8 | 23 | 28 | M5x0.8 | 5.5 | 27.5 | 10 ⁰ _{-0.022} | M10x1.0 | 8 | 5.5 | 35 | 48 | 28 | 38 | 16 | 10 |

| 代號 Code 行程 Stroke 內徑 I.D. | S | | | | | | | | Z | | | | | | | | ZZ | | | | | | | |
|---------------------------------|------|-------|-------|-------|-------|--------|---------|---------|------|-------|-------|-------|-------|--------|---------|---------|------|-------|-------|-------|-------|--------|---------|---------|
| | 5~15 | 16~30 | 31~45 | 46~60 | 61~75 | 76~100 | 101~125 | 126~150 | 5~15 | 16~30 | 31~45 | 46~60 | 61~75 | 76~100 | 101~125 | 126~150 | 5~15 | 16~30 | 31~45 | 46~60 | 61~75 | 76~100 | 101~125 | 126~150 |
| 10 | 45.5 | 53 | 65 | 77 | - | - | - | - | 81.5 | 89 | 101 | 113 | - | - | - | - | 92.5 | 100 | 112 | 124 | - | - | - | - |
| 16 | 45.5 | 54 | 66 | 78 | 84 | 108 | 126 | 138 | 83.5 | 92 | 104 | 116 | 122 | 146 | 164 | 176 | 97.5 | 106 | 118 | 130 | 136 | 160 | 178 | 190 |

筆型氣壓缸
Pen Cylinders

FMJ

Y 接頭 / Y Connector

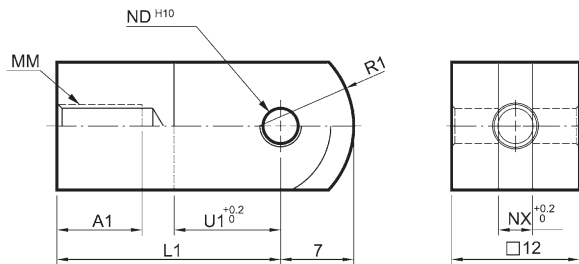

| 代號 Code 內徑 Tube I.D. | A1 | L1 | MM | HD ^{H10} | NX | R1 | U1 |
|-------------------------|----|----|----------|------------------------------------|-----|----|----|
| 10 | 8 | 21 | M4 × 0.7 | 3.3 ^{+0.048} ₀ | 3.2 | 8 | 10 |
| 16 | 11 | 21 | M5 × 0.8 | 5 ^{+0.048} ₀ | 6.5 | 12 | 10 |

I 接頭 / I Connector

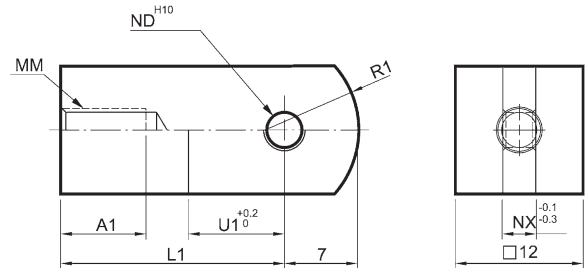

| 代號 Code 內徑 Tube I.D. | A1 | L1 | MM | HD ^{H10} | NX | R1 | U1 |
|-------------------------|----|----|----------|------------------------------------|-----|----|----|
| 10 | 8 | 21 | M4 × 0.7 | 3.3 ^{+0.048} ₀ | 3.1 | 8 | 9 |
| 16 | 8 | 25 | M5 × 0.8 | 5 ^{+0.048} ₀ | 6.4 | 12 | 14 |

訂購代碼 Ordering Code

PIN – FMJ – 10 – Y – P

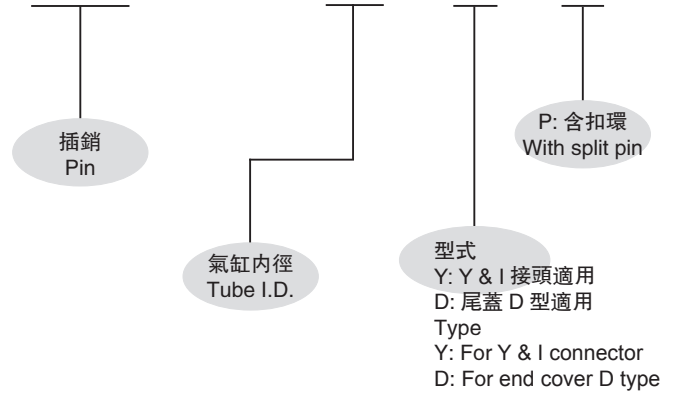

插銷 / Pin

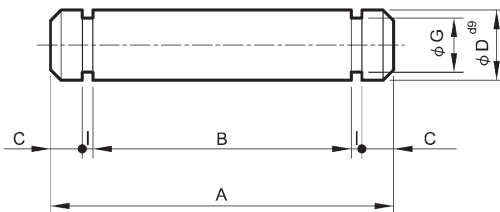

適用於 I 型 & Y 型接頭 For I & Y connector

| 代號 Code 內徑 Tube I.D. | A | B | C | D ^{d9} | G | I | 扣環 Split pin |
|-------------------------|------|------|-----|---------------------------------------|-----|-----|-----------------|
| 10 | 16.2 | 12.2 | 1.5 | 3.3 ^{-0.03} _{-0.06} | 2.5 | 0.5 | E-2.5 |
| 16 | 16.2 | 12.2 | 1.5 | 5 ^{-0.03} _{-0.06} | 4 | 0.7 | E-4 |

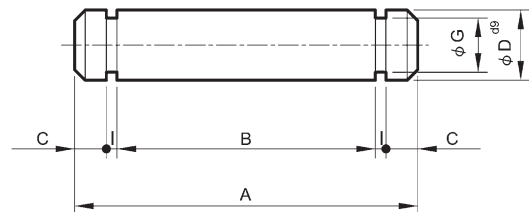

適用於尾蓋 D 型 For end cover D type

| 代號 Code 內徑 Tube I.D. | A | B | C | D ^{d9} | G | I | 扣環 Split pin |
|-------------------------|------|------|-----|---------------------------------------|-----|-----|-----------------|
| 10 | 15.2 | 12.2 | 1 | 3.3 ^{-0.03} _{-0.06} | 2.5 | 0.5 | E-2.5 |
| 16 | 22.7 | 18.3 | 1.5 | 5 ^{-0.03} _{-0.06} | 4 | 0.7 | E-4 |